

MAvRIC

Multi-Agent and Advanced
Robotics Centre

A DfE-funded HERC State-of-the-Art Teaching
and Research Facility

Dr Mark Ng, SMIEEE

Reader, School of Engineering, Ulster University

Adjunct Senior Research Fellow, School of Engineering, Monash University

Vice-Chair, IEEE UK and Ireland Control Systems Chapter

EPSRC ILN+ Researcher in Residence with Digital Catapult

June 2026



Digital Twin of an Automotive Engine System



Digital Twin of an Automotive Engine System



Physical Automotive Vehicle



volvocars.com

Understanding of Engine Dynamics



volvocars.com

Identifying Faults of Interest

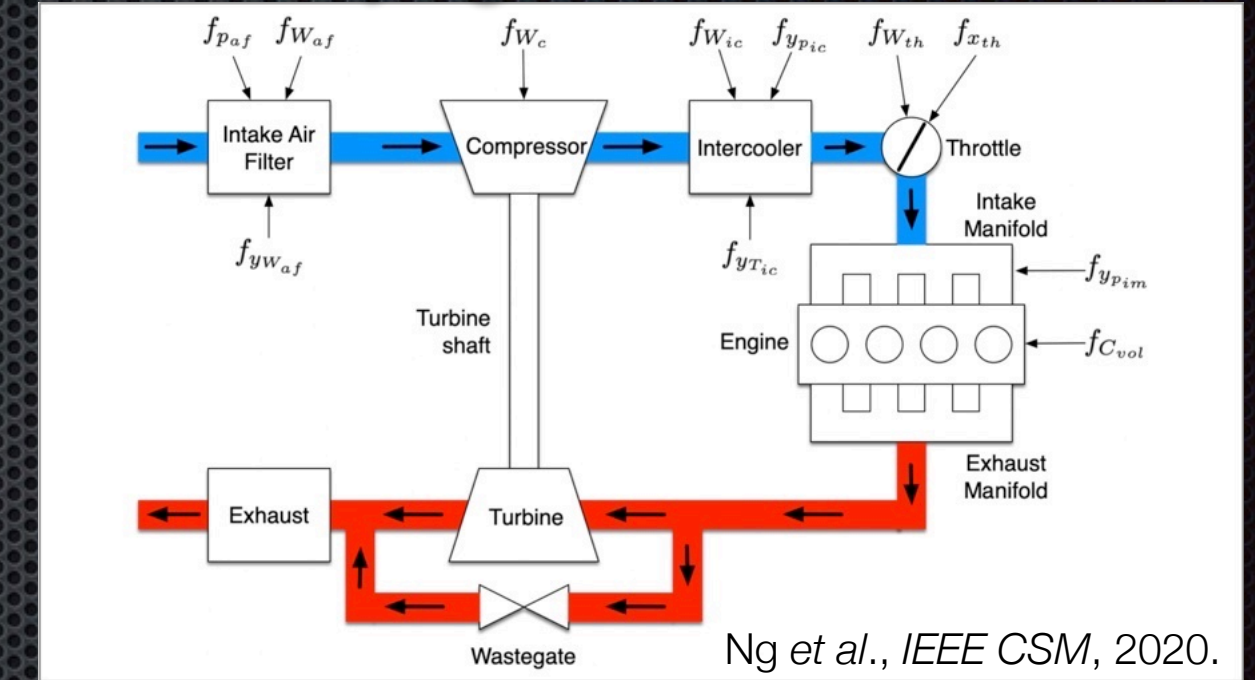

Ng et al., IEEE CSM, 2020.

Verification of Engine Model and Controller Design

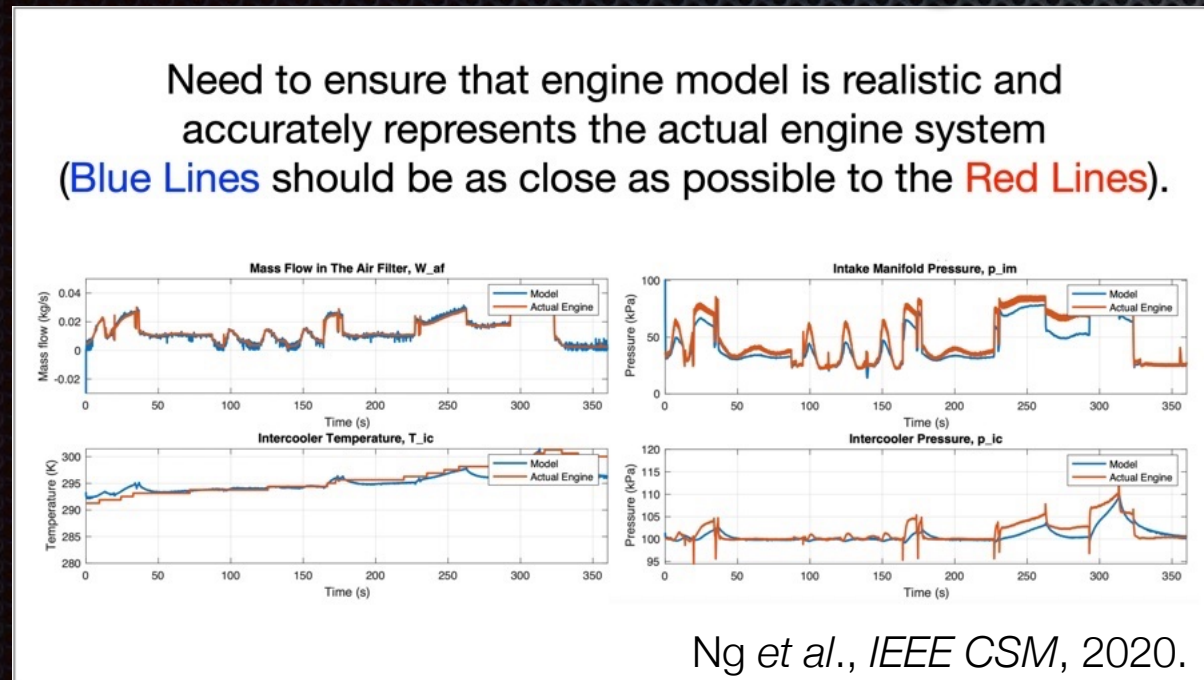

Ng et al., IEEE CSM, 2020.

Controller Design

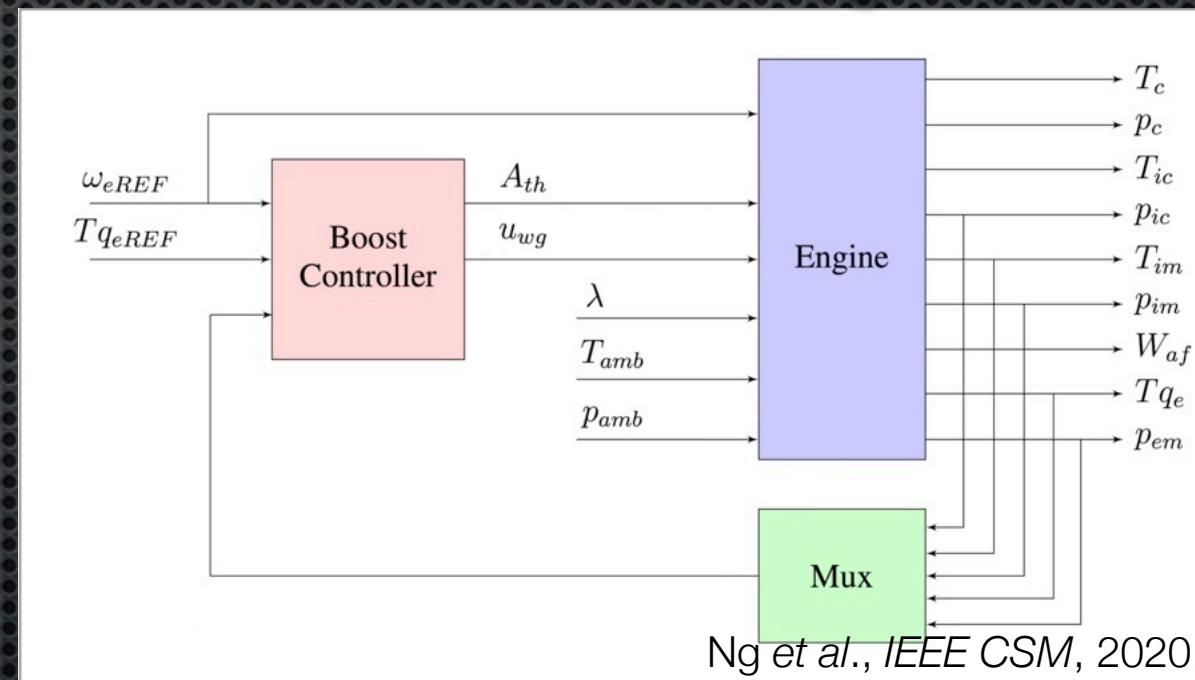

Ng et al., IEEE CSM, 2020.

Modelling of Engine System

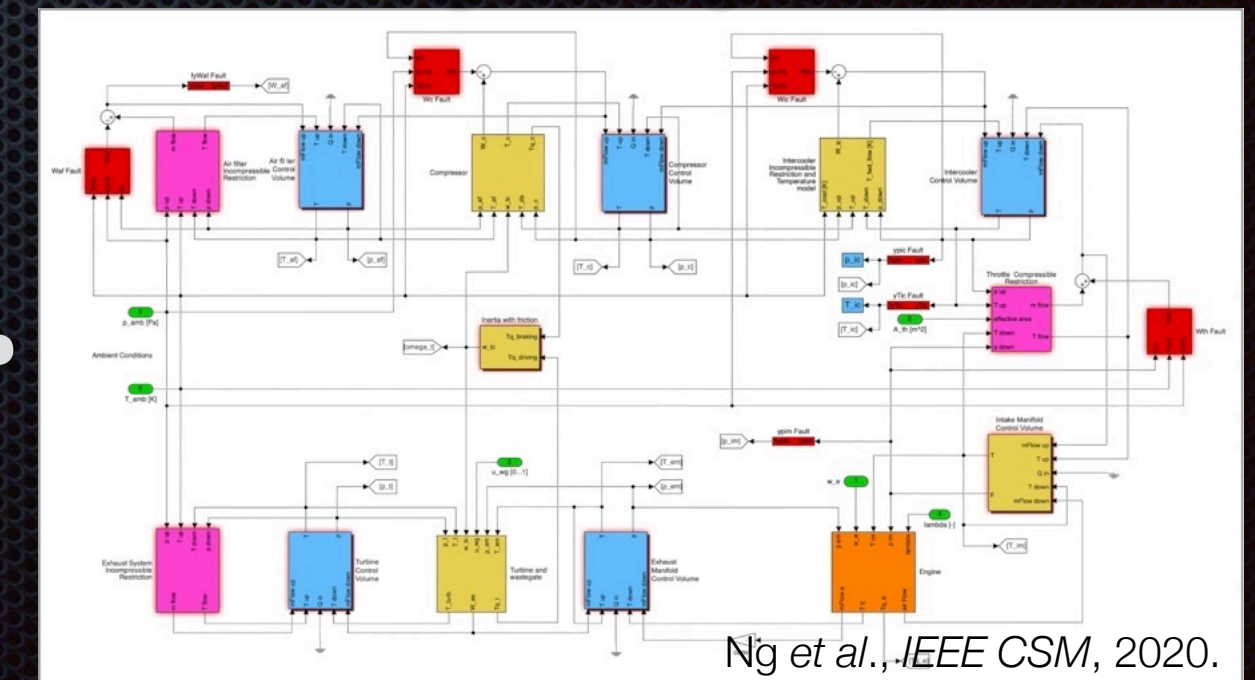

Ng et al., IEEE CSM, 2020.

Simulation Testbed



- Realistic modelling and control of the engine
- Injection and simulation of various actuator, sensor, and variable faults
- Testing of algorithms for additional monitors/residuals selection
- Testing of algorithms for fault diagnosis

Main GUI

Turbocharged Petrol Engine System: Simulation Testbed For Fault Diagnosis

Mark Ng : mark.ng@ulster.ac.uk
 Erik Frisk : erik.frisk@liu.se
 Mattias Krysander : mattias.krysander@liu.se
 Lars Eriksson : lars.eriksson@liu.se

Fault Mode:

Leakage at Throttle (fWth) ⌵

Driving Cycle:

WLTP ⌵

Simulation Mode:

Simulate Engine + Generate Residuals + Run FI ⌵

RUN SIMULATION

EXIT

Simulation Log

Simulation for fW_th Scenario

Driving Cycle: WLTP (1800 seconds)

Generating reference signals..... [DONE]
 Loading engine system..... [DONE]
 Simulating engine system..... [DONE]

Simulating Residuals..... [DONE]
 Residuals Generated.

Plotting residual signals..... [DONE]

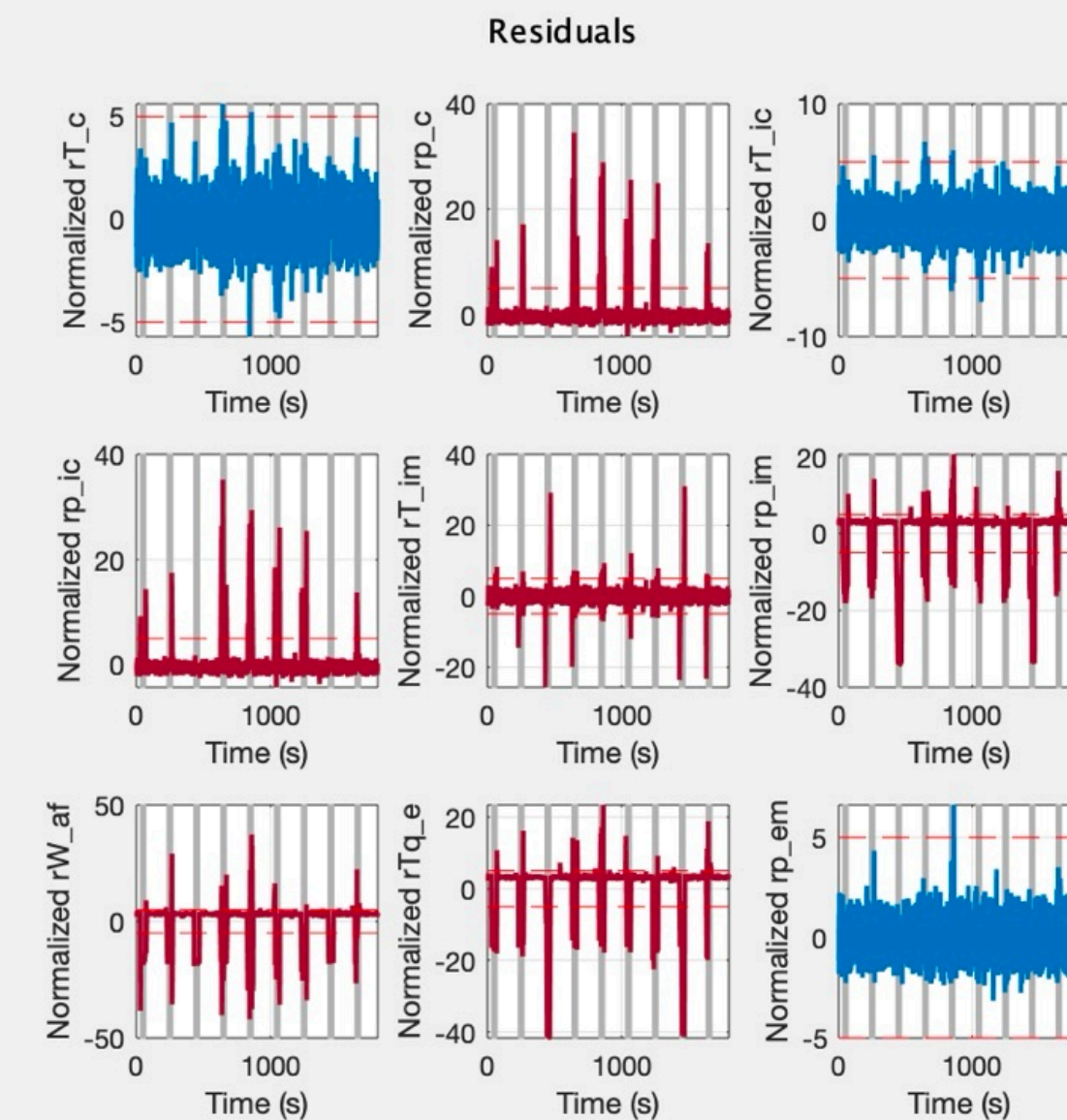
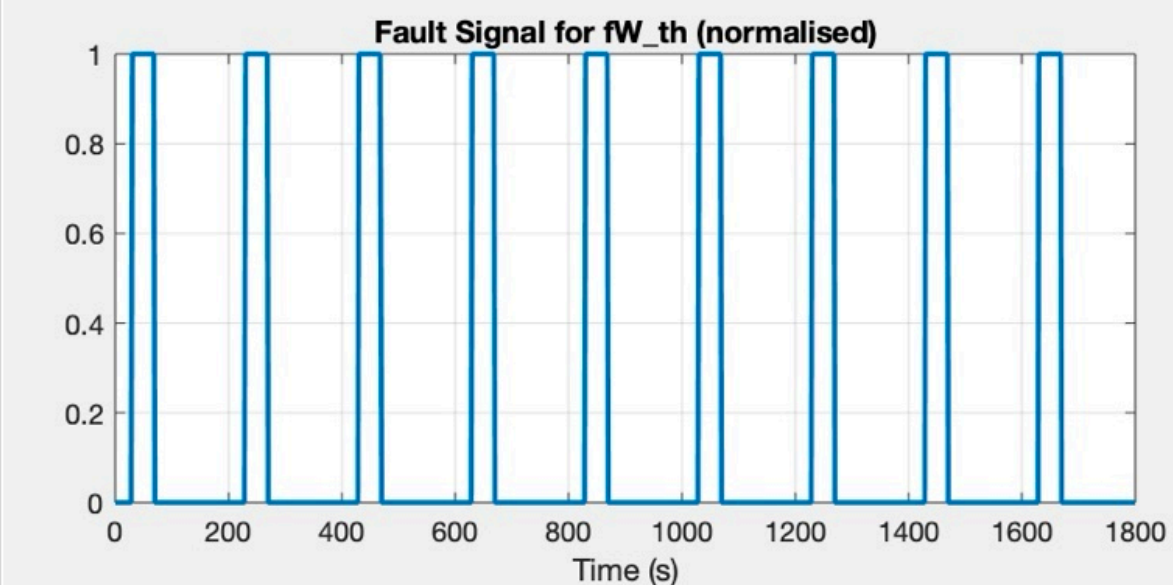
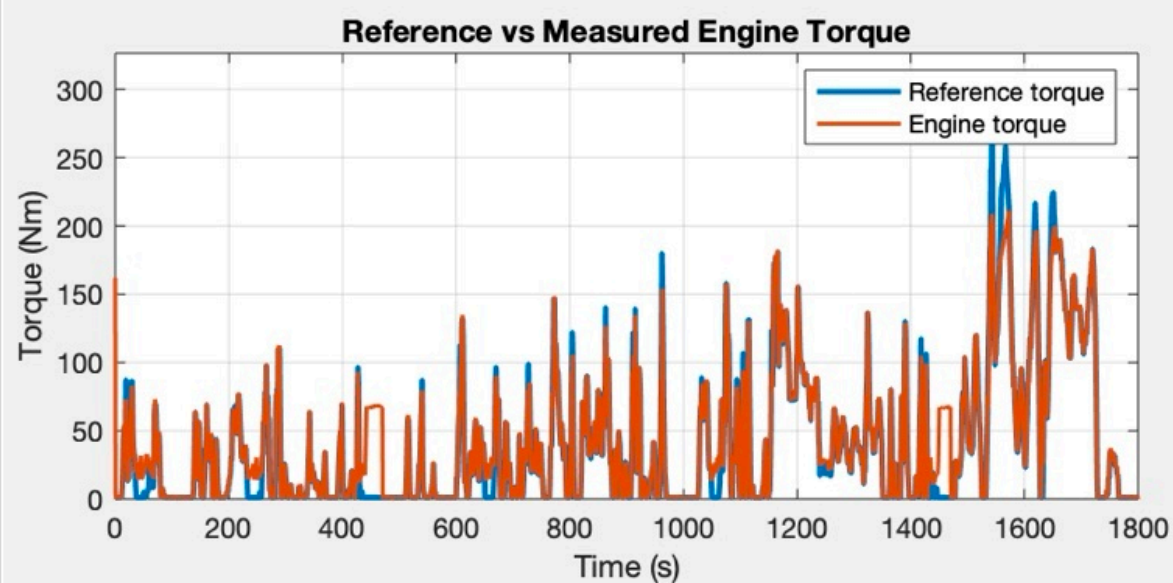
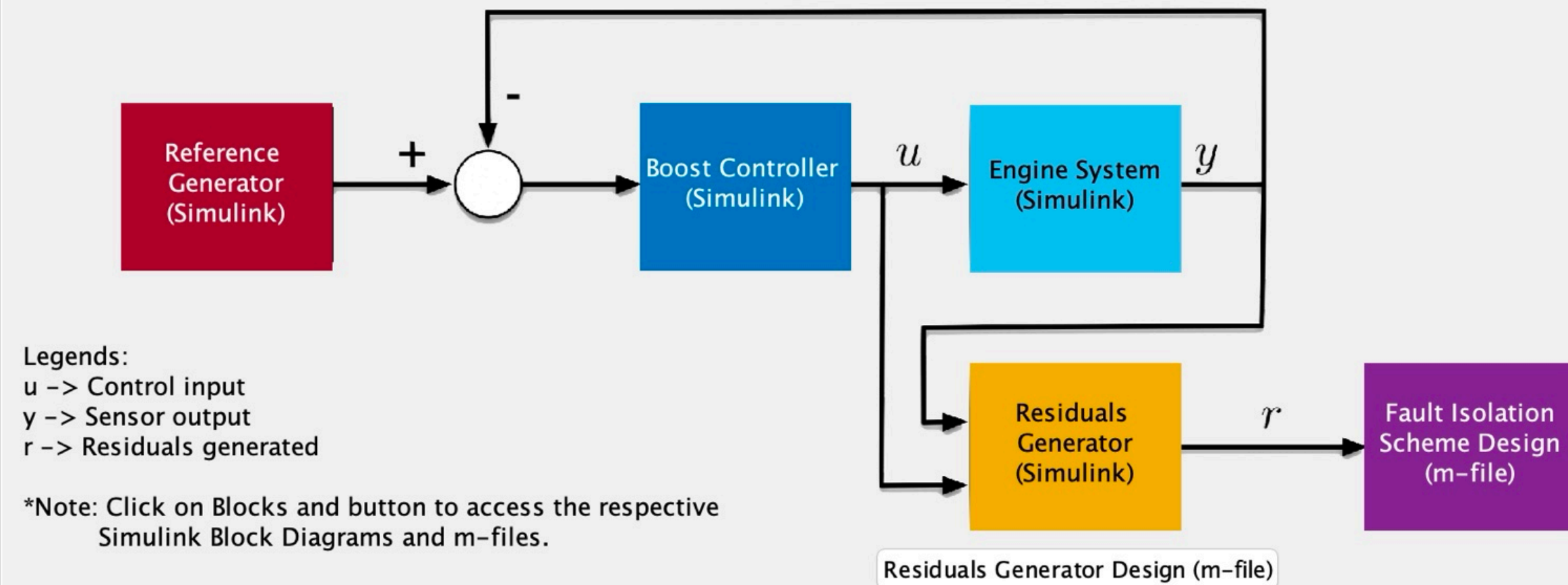

Main GUI

- Driving Cycle Profile:
- WLTP
 - NEDC
 - EUDC
 - FTP-75

- Fault Mode:
- Fault-free
 - 11 faults

- Blocks to access M-files and Simulink Models:
- Reference signals generator (Simulink)
 - Controller and engine model (Simulink)
 - Residuals generator (m-file and Simulink)
 - Fault diagnosis scheme design (m-file)

Open-source for
Research and Teaching

www.markusng.com/TCSI



**Turbocharged Petrol Engine System:
Simulation Testbed For Fault Diagnosis**

Mark Ng : mark.ng@ulster.ac.uk
Erik Frisk : erik.frisk@liu.se
Mattias Krysander : mattias.krysander@liu.se
Lars Eriksson : lars.eriksson@liu.se

Fault Mode:
Leakage at Throttle (fWth)

Driving Cycle:
WLTP

Simulation Mode:
Simulate Engine + Generate Residuals + Run FI

RUN SIMULATION EXIT

Simulation Log

Simulation for fW_th Scenario

Driving Cycle: WLTP (1800 seconds)

Generating reference signals..... [DONE]
Loading engine system..... [DONE]
Simulating engine system..... [DONE]

Simulating Residuals..... [DONE]
Residuals Generated.

Plotting residual signals..... [DONE]

Reference vs Measured Engine Torque

Reference torque
Engine torque

Torque (Nm)

Time (s)

Fault Signal for fW_th (normalised)

Time (s)

Residuals

Normalized rT_ic
Normalized rp_c
Normalized rT_lm
Normalized rp_lm
Normalized rW_af
Normalized rTQ_e
Normalized rp_em

Time (s)

Legends:
u -> Control input
y -> Sensor output
r -> Residuals generated

*Note: Click on Blocks and button to access the respective Simulink Block Diagrams and m-files.

Residuals Generator Design (m-file)

- Simulation Mode:
- Simulate engine only
 - Simulate engine with residuals generation and FD schemes

Simulation log to show progress (and results)

Buttons to Run simulation and to Exit the GUI

- Graphical plots:
- Tq_eREF vs Tq_e
 - Fault signal
 - Residuals

Demo

Nominal Fault-free Scenario

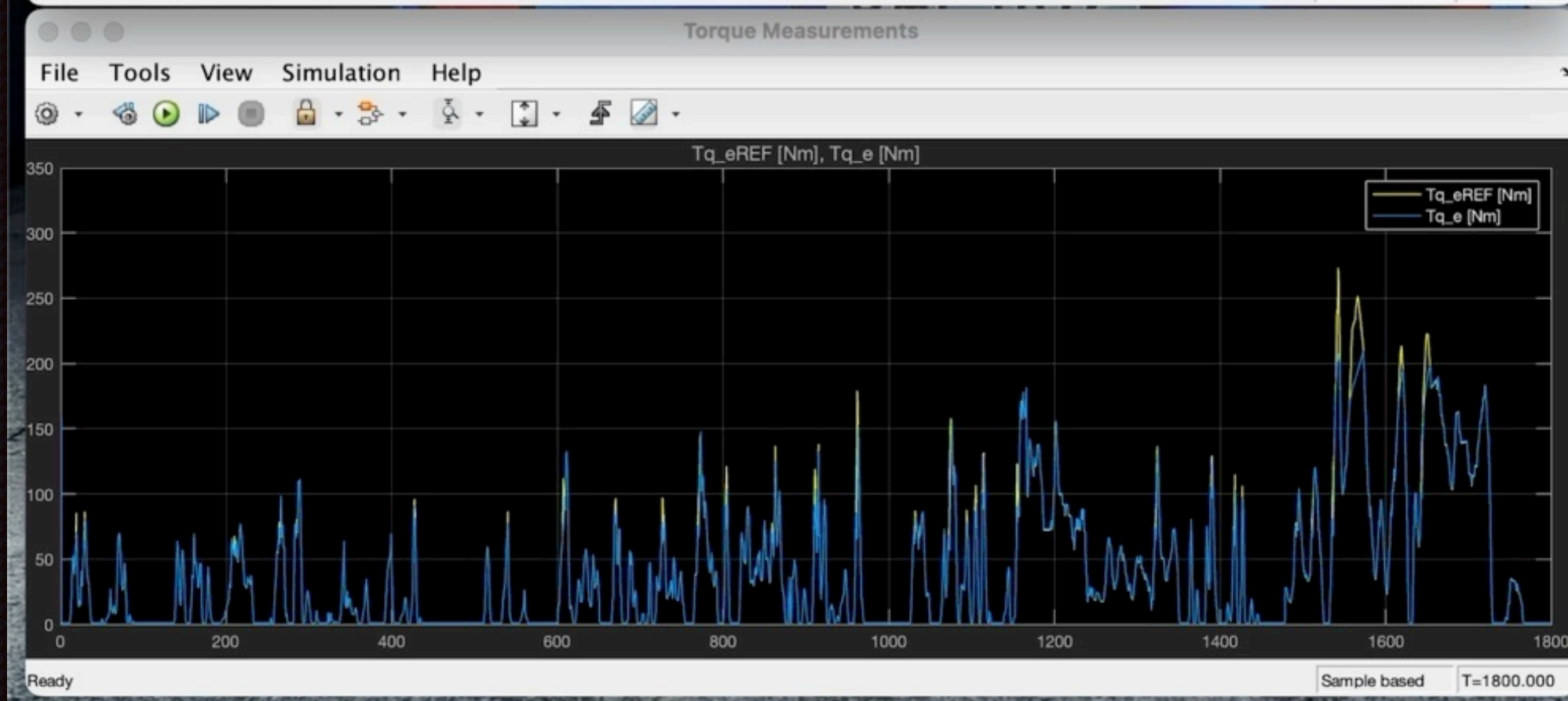
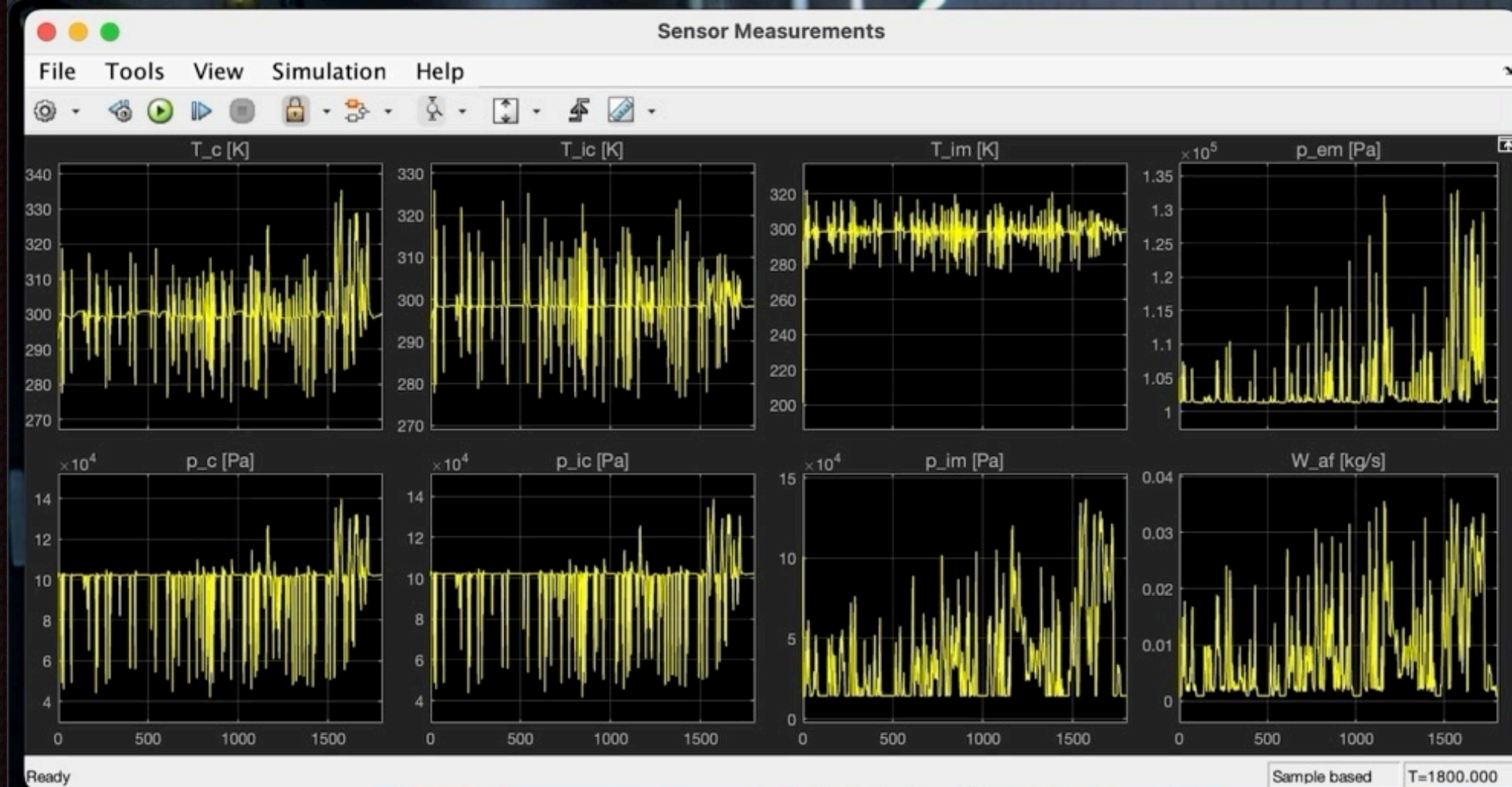

Turbocharged Petrol Engine System: Simulation Testbed For Fault Diagnosis

Mark Ng : mark.ng@ulster.ac.uk
Erik Frisk : erik.frisk@liu.se
Mattias Krysander : mattias.krysander@liu.se
Lars Eriksson : lars.eriksson@liu.se

Fault Mode: Fault-free
Driving Cycle: WLTP
Simulation Mode: Simulate Engine + Generate Residuals + Run FI

RUN SIMULATION EXIT

Simulation Log

```
Simulation for No_fault Scenario
-----
Driving Cycle: WLTP (1800 seconds)
-----
Generating reference signals..... [ DONE ]
Loading engine system..... [ DONE ]
Simulating engine system..... [ DONE ]
-----
Simulating Residuals..... [ DONE ]
Residuals Generated.
-----
Plotting residual signals..... [ DONE ]
-----
```

main

Block diagram showing the simulation setup:

- Reference Generator (Simulink) outputs u .
- Boost Controller (Simulink) receives u and outputs y .
- Engine System (Simulink) receives y and outputs r .
- Residuals Generator (Simulink) receives r and outputs r .
- Fault Isolation Scheme Design (m-file) receives r .

Legends:
 u -> Control input
 y -> Sensor output
 r -> Residuals generated

*Note: Click on Blocks and button to access the respective Simulink Block Diagrams and m-files.

Residuals Generator Design (m-file)

Reference vs Measured Engine Torque plot showing Reference torque (blue) and Engine torque (orange) over time (0 to 1800 seconds). The torque values range from 0 to 300 Nm.

Fault Signal for No_fault (normalised) plot showing a constant zero signal over time (0 to 1800 seconds).

Residuals plots showing normalized residuals for various parameters over time (0 to 1000 seconds):

- Normalized r_{T_c}
- Normalized r_{p_c}
- Normalized $r_{T_{ic}}$
- Normalized $r_{p_{ic}}$
- Normalized $r_{T_{im}}$
- Normalized $r_{p_{im}}$
- Normalized $r_{W_{af}}$
- Normalized $r_{T_{q_e}}$
- Normalized $r_{p_{em}}$

2x Speed

Scenario with Fault: Air Filter Mass Flow Sensor Error

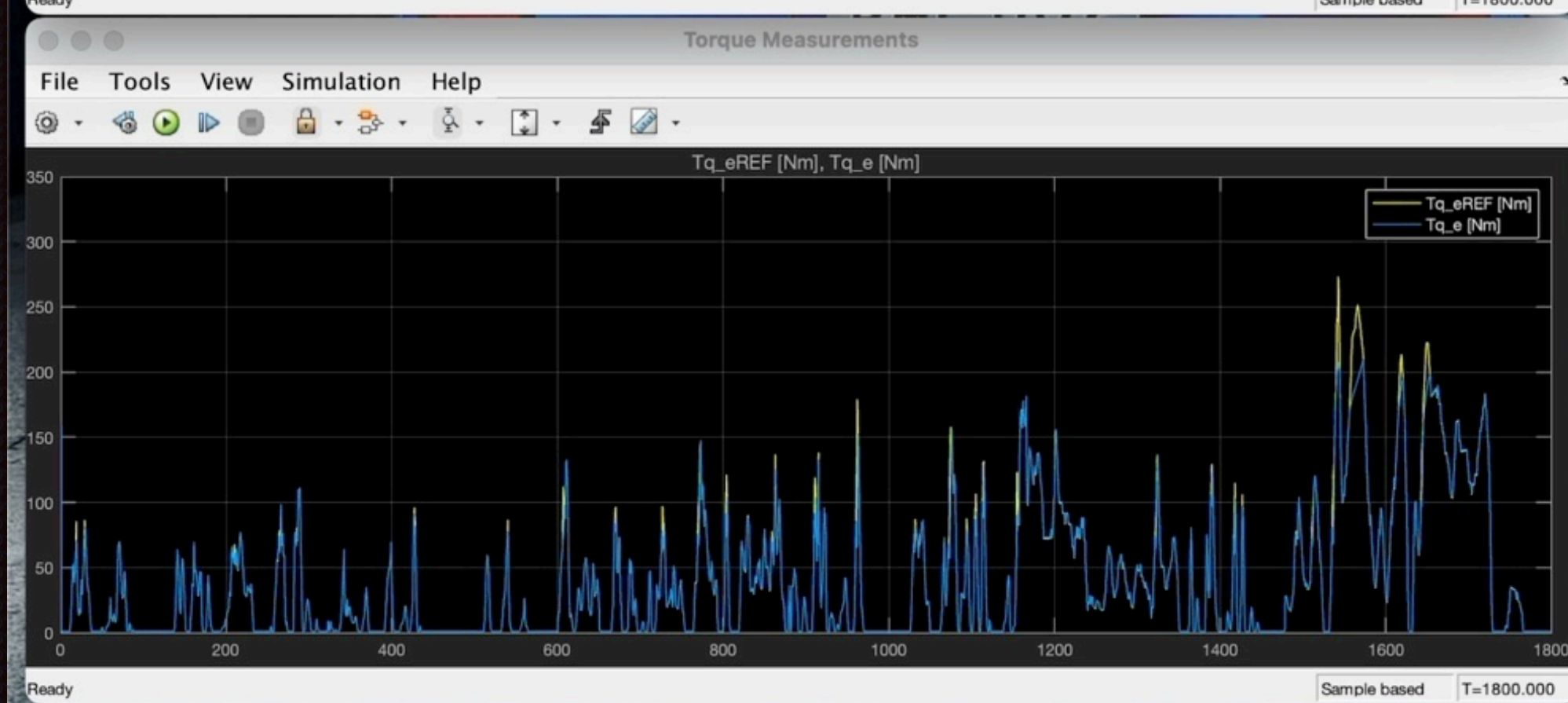
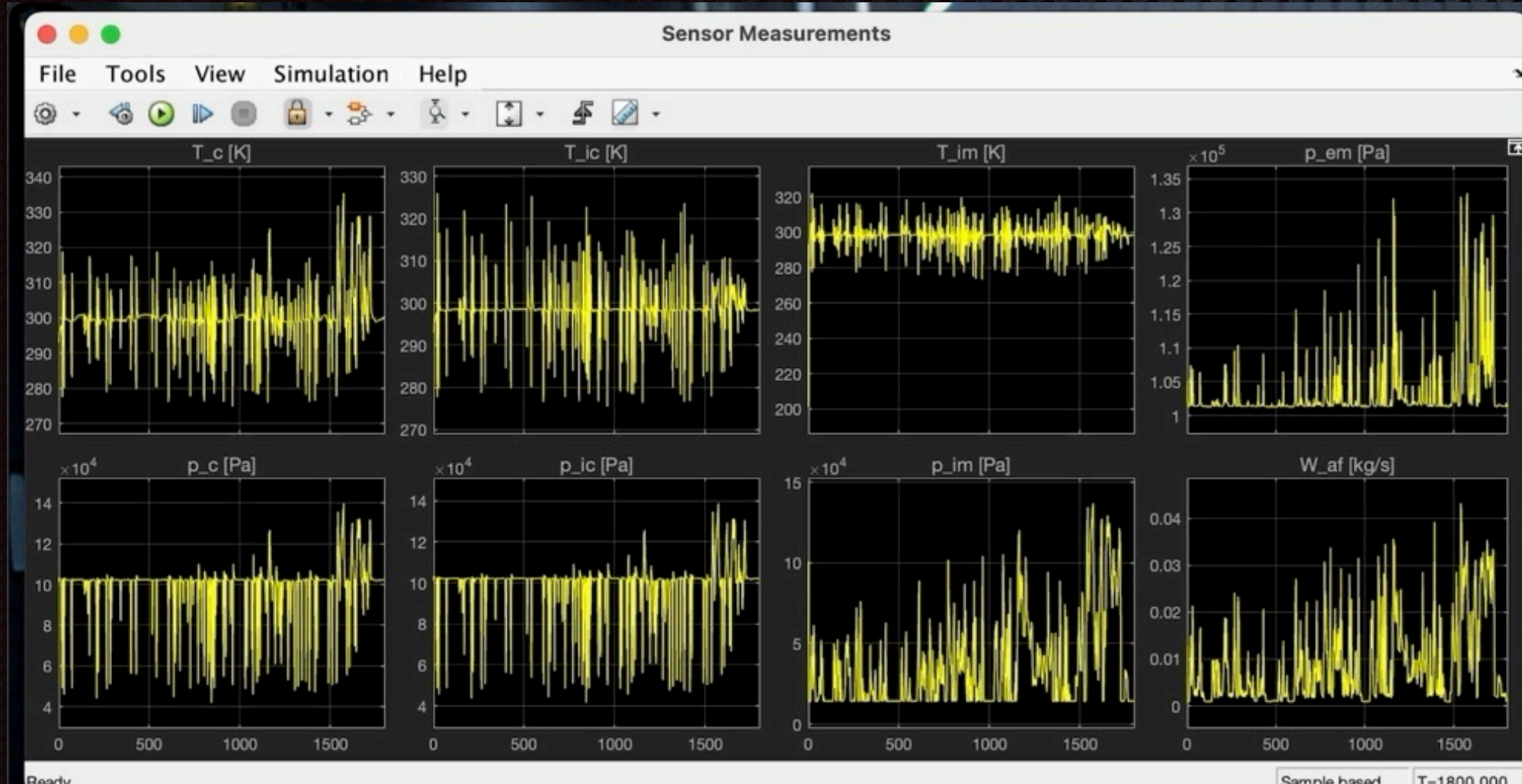

Turbocharged Petrol Engine System: Simulation Testbed For Fault Diagnosis

Mark Ng : mark.ng@ulster.ac.uk
 Erik Frisk : erik.frisk@liu.se
 Mattias Krysander : mattias.krysander@liu.se
 Lars Eriksson : lars.eriksson@liu.se

Fault Mode:

Driving Cycle:

Simulation Mode:

```

Simulation Log
-----
Simulation for fyW_af Scenario
-----
Driving Cycle: WLTP (1800 seconds)
-----
Generating reference signals..... [ DONE ]
Loading engine system..... [ DONE ]
Simulating engine system..... [ DONE ]
-----
Simulating Residuals..... [ DONE ]
Residuals Generated.
-----
Plotting residual signals..... [ DONE ]
                    
```

main

Legends:
 u -> Control input
 y -> Sensor output
 r -> Residuals generated

*Note: Click on Blocks and button to access the respective Simulink Block Diagrams and m-files.

Residuals Generator Design (m-file)

Reference vs Measured Engine Torque

Fault Signal for fyW_af (normalised)

Residuals

2x Speed

v2.0 releasing soon...

Turbocharged Petrol Engine System: Offline Digital Twin for Fault Diagnosis

Mark Ng : mark.ng@ulster.ac.uk
Erik Frisk : erik.frisk@liu.se
Mattias Krysander : mattias.krysander@liu.se
Lars Eriksson : lars.eriksson@liu.se

Fault Mode:

Driving Cycle:

Simulation Mode:

RUN SIMULATION **QUIT**

Simulation Log

Simulation for fp_af Scenario

Driving Cycle: WLTP (1800 seconds)

Generating reference signals..... [OK]
Loading engine system..... [OK]
Simulating engine system..... [OK]

Closed-loop Control System

Residuals Generator and Fault Diagnosis

Click here to open Simulink model

Torque [Nm]

Fault Signal for fp_af (normalised)

T_c [K]

T_ic [K]

T_im [K]

p_em [Pa]

p_c [Pa]

p_ic [Pa]

p_im [Pa]

W_af [kg/s]

Fault Diagnosis

Fault Diagnosis

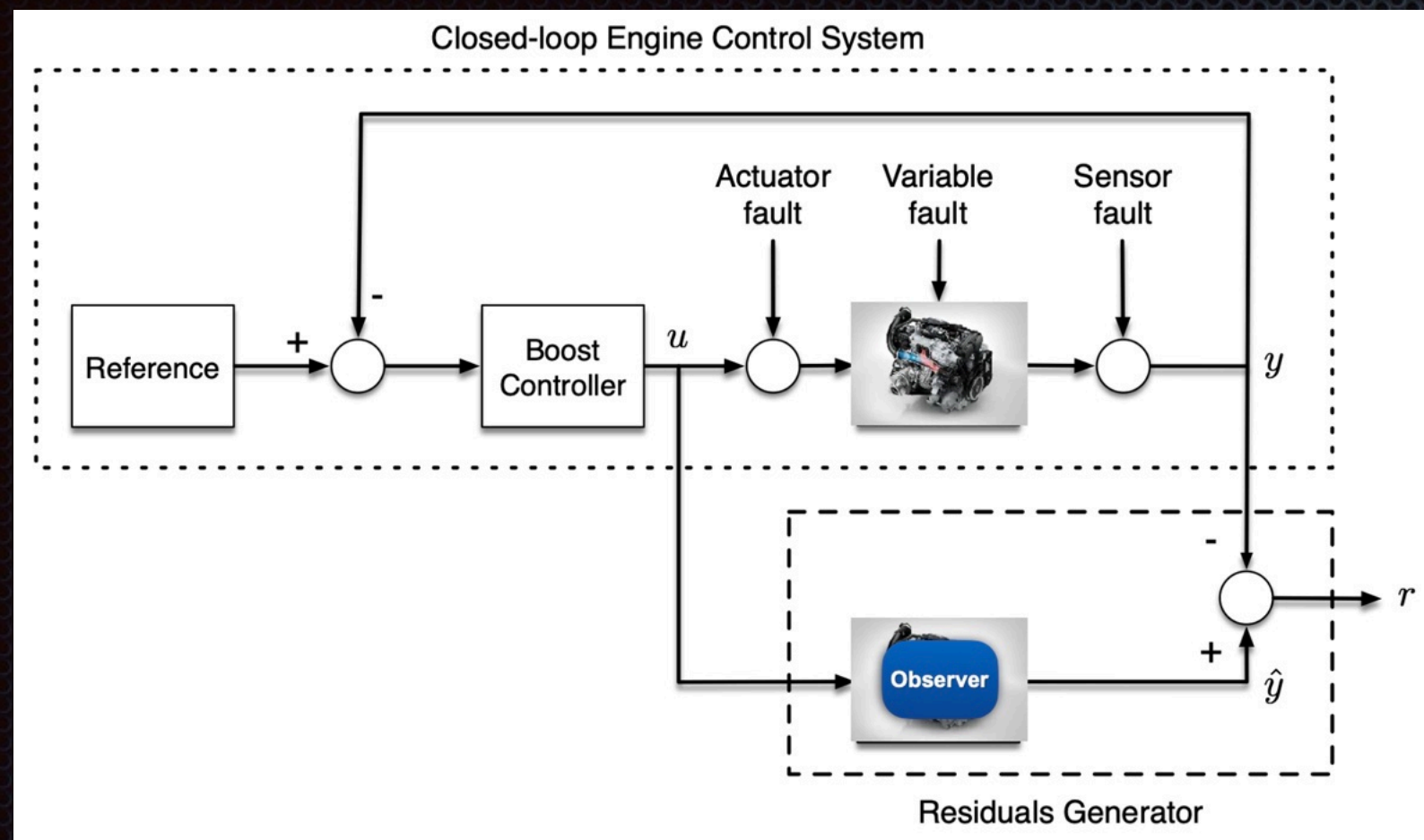

Closed-loop engine control system and the residuals generator

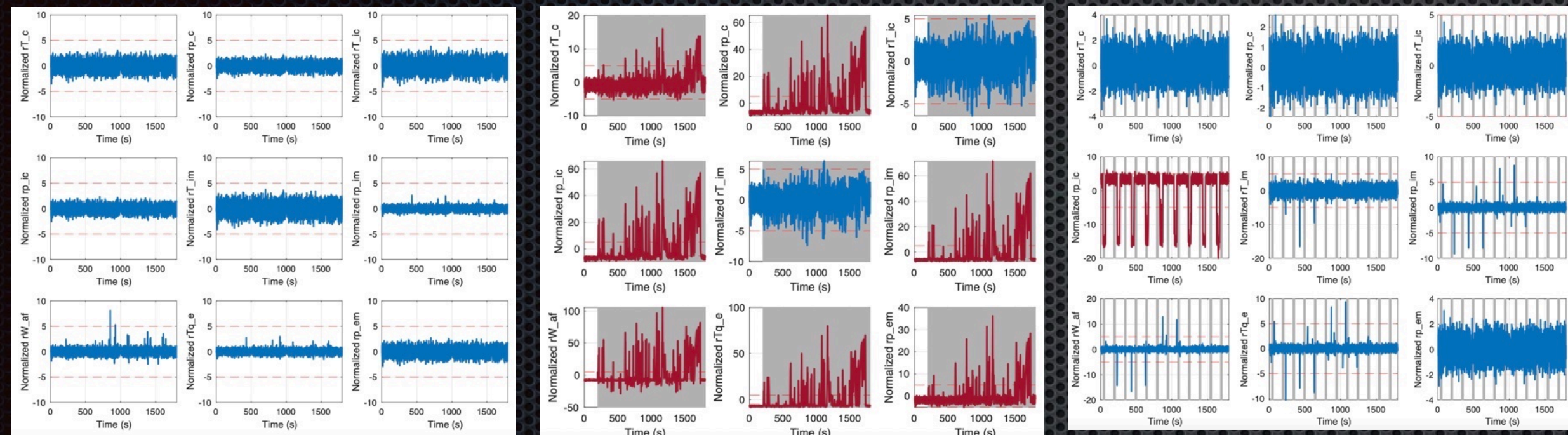

Nominal

Pressure fault in air filter

Intercooler pressure sensor fault

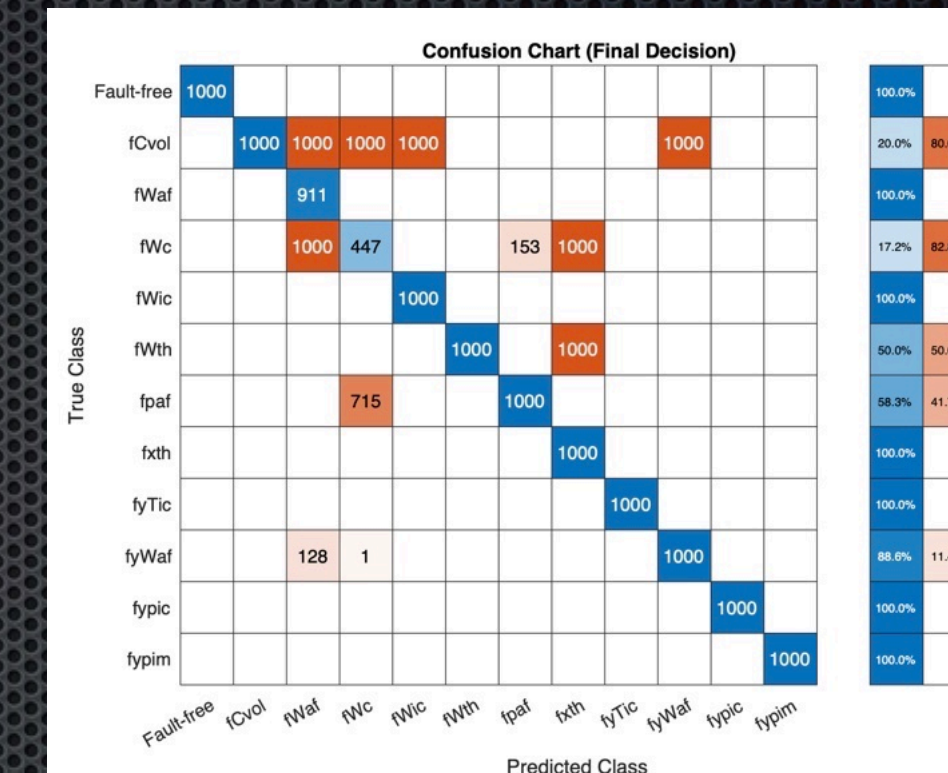
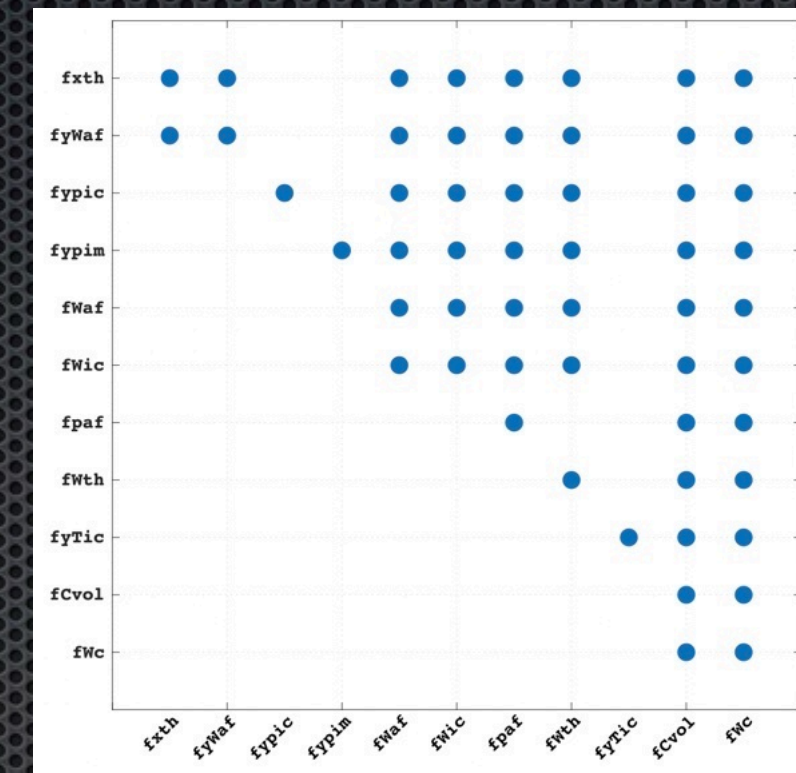

Fault isolation analysis

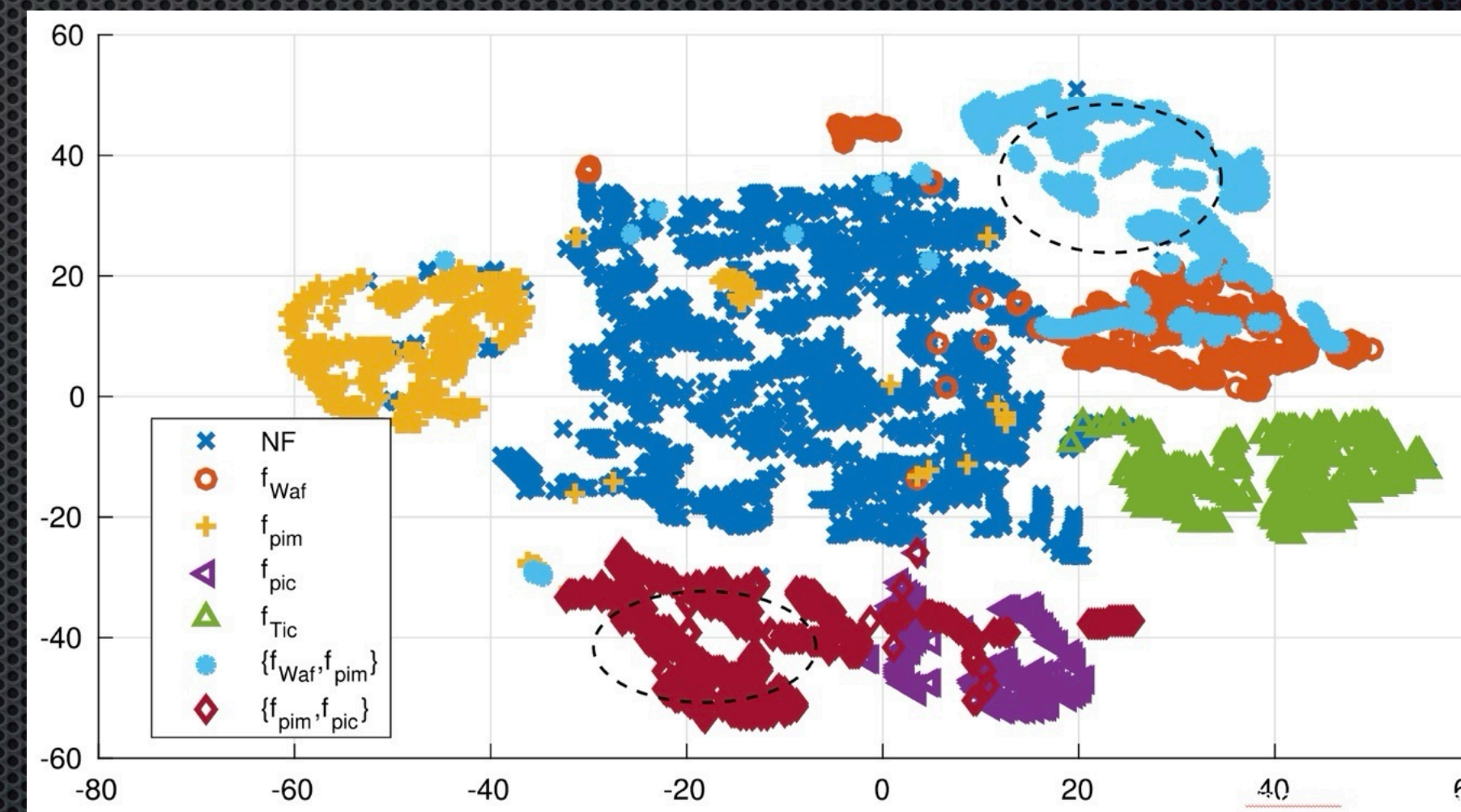

Fig. 11. Visualization of residual data using t-SNE from all single-faults and the two double-fault scenarios.

Visualising residual data using dimensional reduction technique



IEEE CSM Paper



CEP Paper



IEEE CoDIT Paper



SysTol Paper

Fault Diagnosis

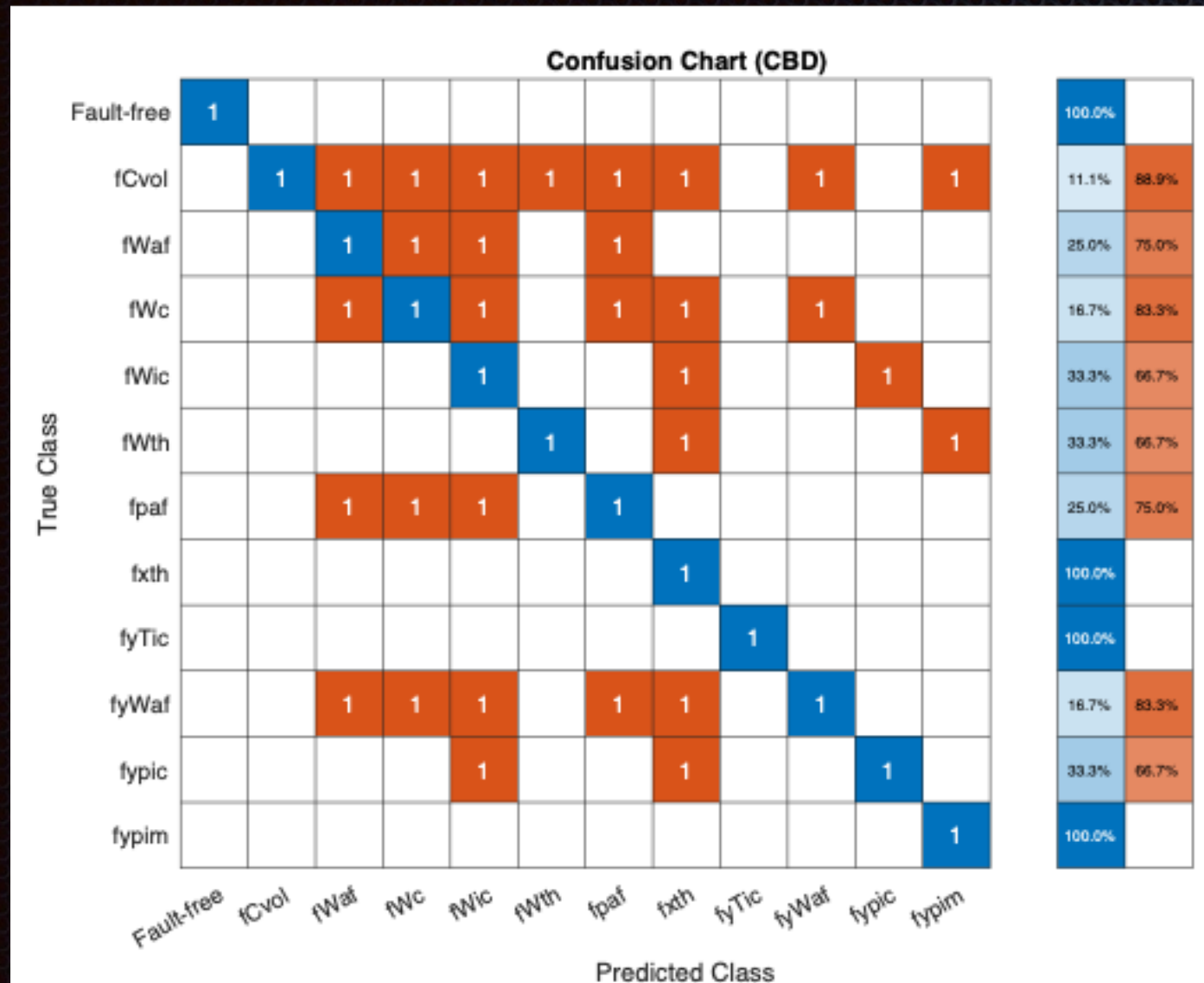

Method A

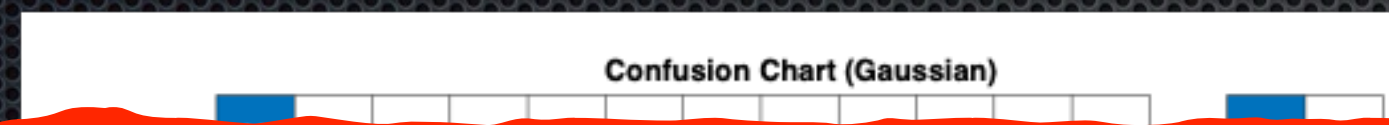

DfT showcased and featured this research at the OECD ITF 2025 in Leipzig, Germany as part of current UK research related to transport digital twinning.

Method B

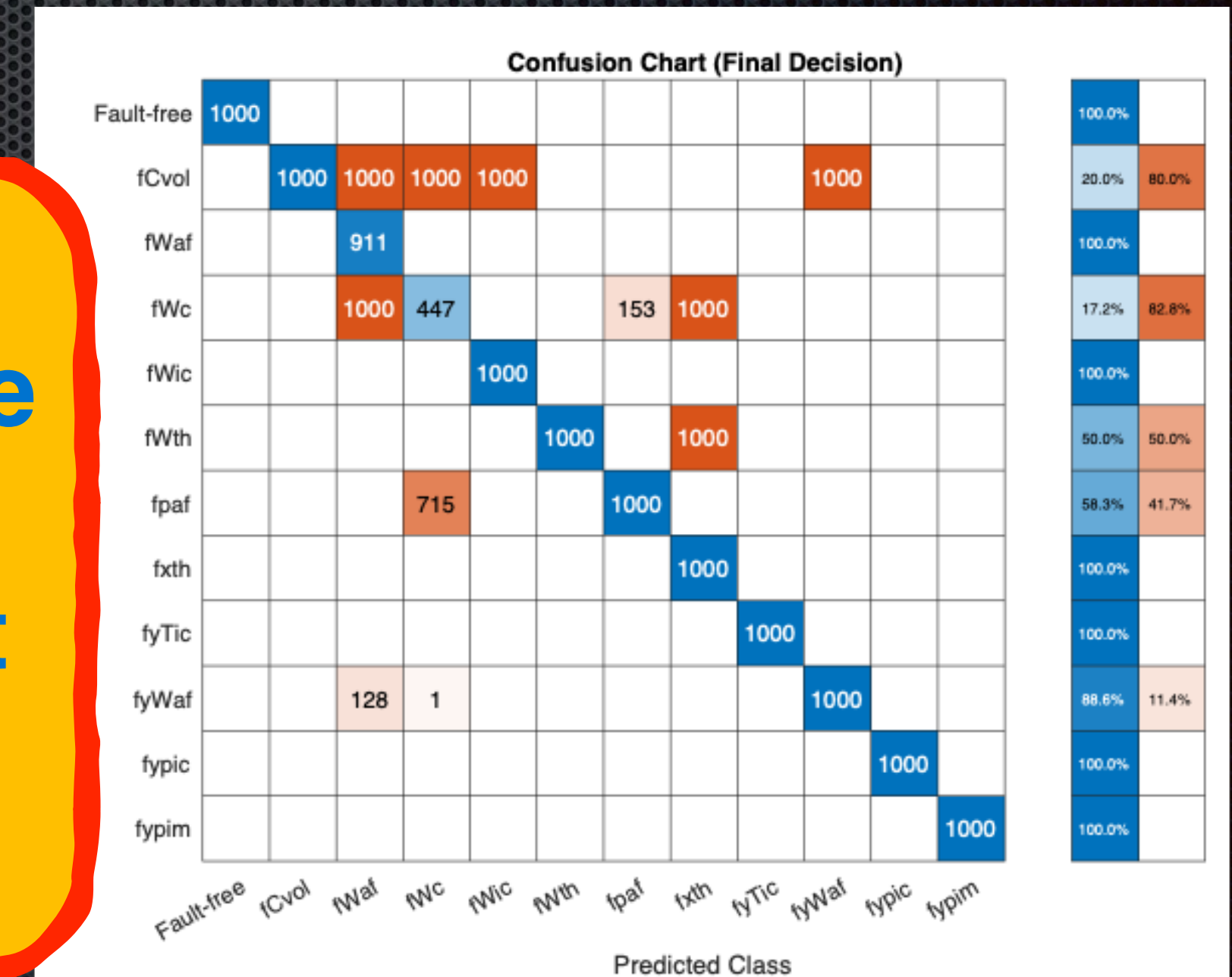

Final Decision

Ng et al., IEEE CSM, 2020.

Jung et al., CEP, 2018.

Ng et al., IEEE CoDIT'20, 2020.

Jung et al., SysTol, 2016.

Digital Shadow of a Manufacturing System



Technische
Hochschule
Augsburg



TTZ Nördlingen
Flexible Automation

Digital Shadow of a Manufacturing System

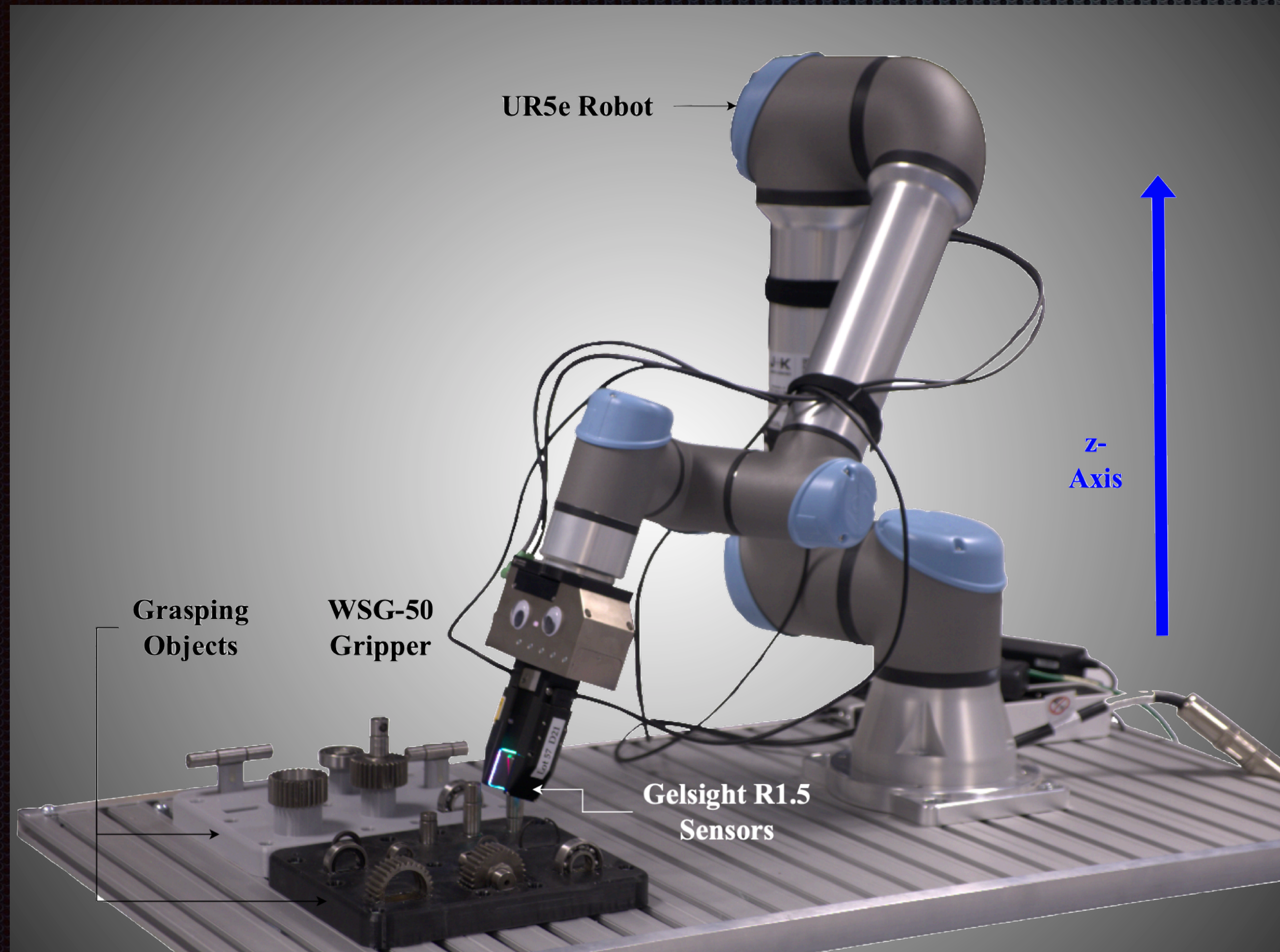

Actual physical system

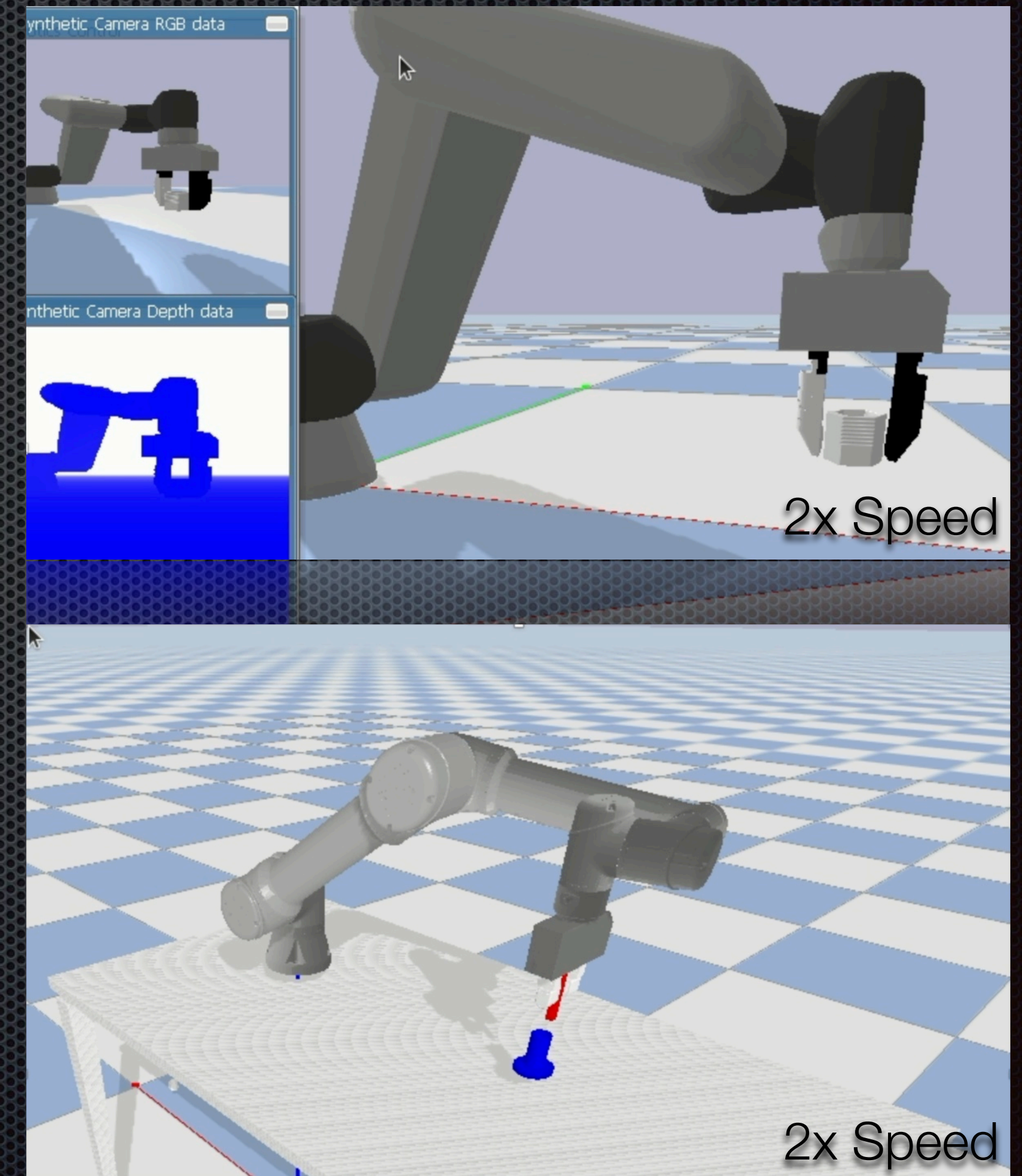

Digital shadow

Digital Shadow of a Manufacturing System

Grip Force Prediction and Optimisation

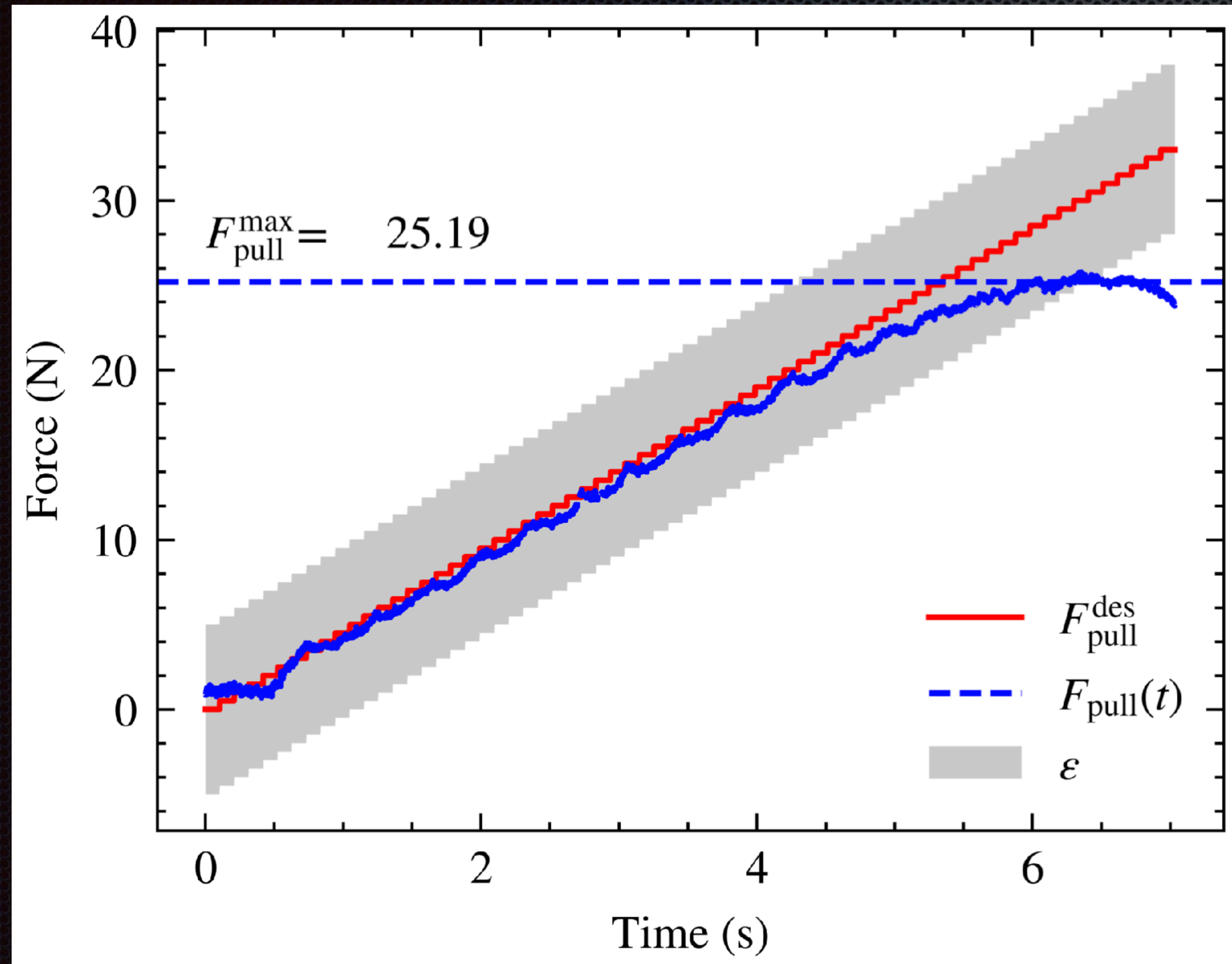

Synthetic vs Real Data

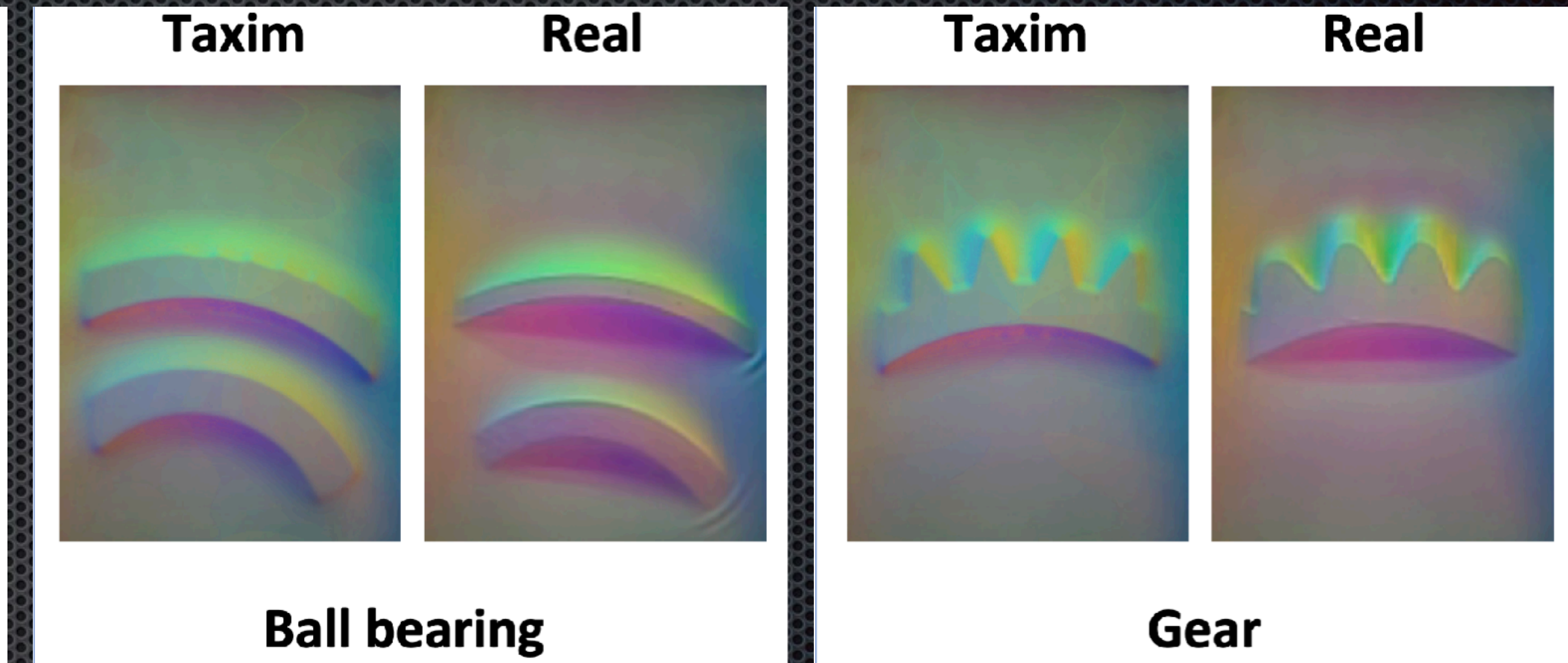

Digital Shadow of a Manufacturing System

Diffusion Model zur robusten Generierung synthetischer Gelicht RGB-Bilder von Tiefe

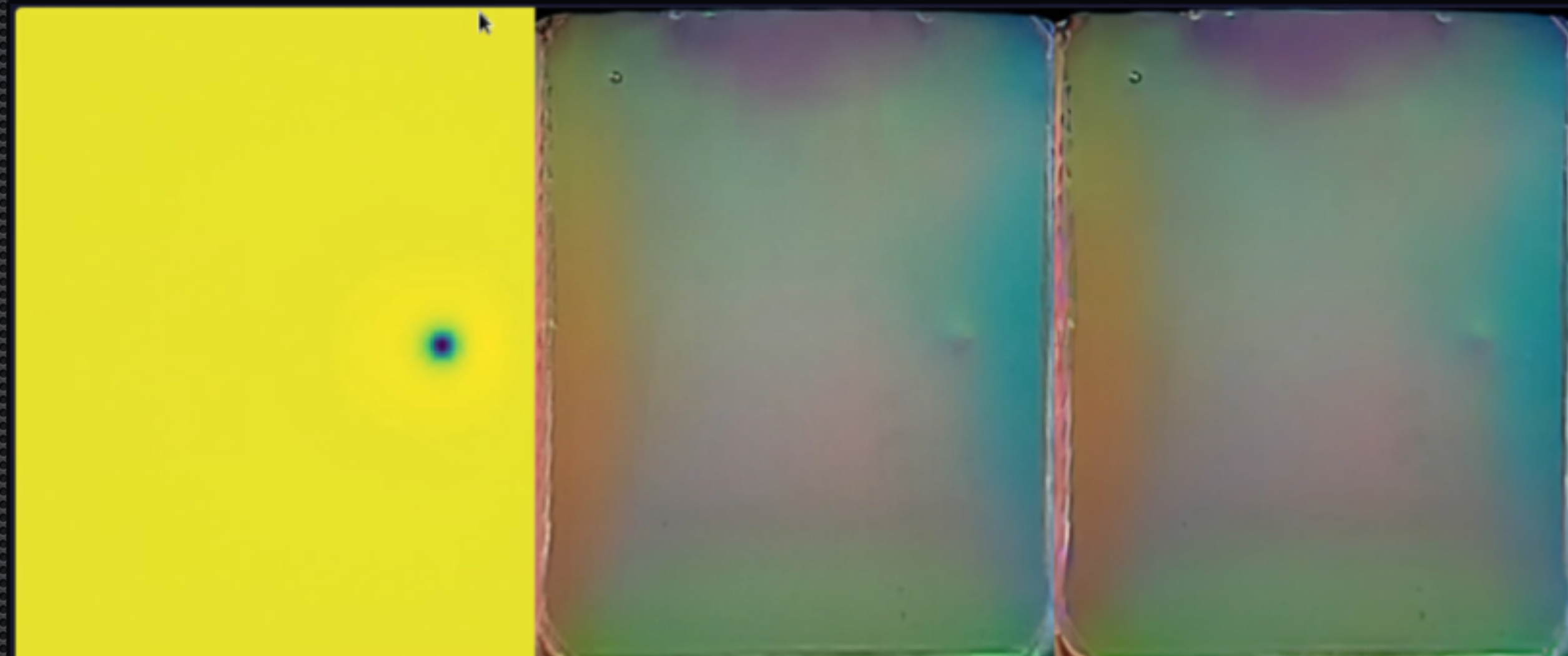
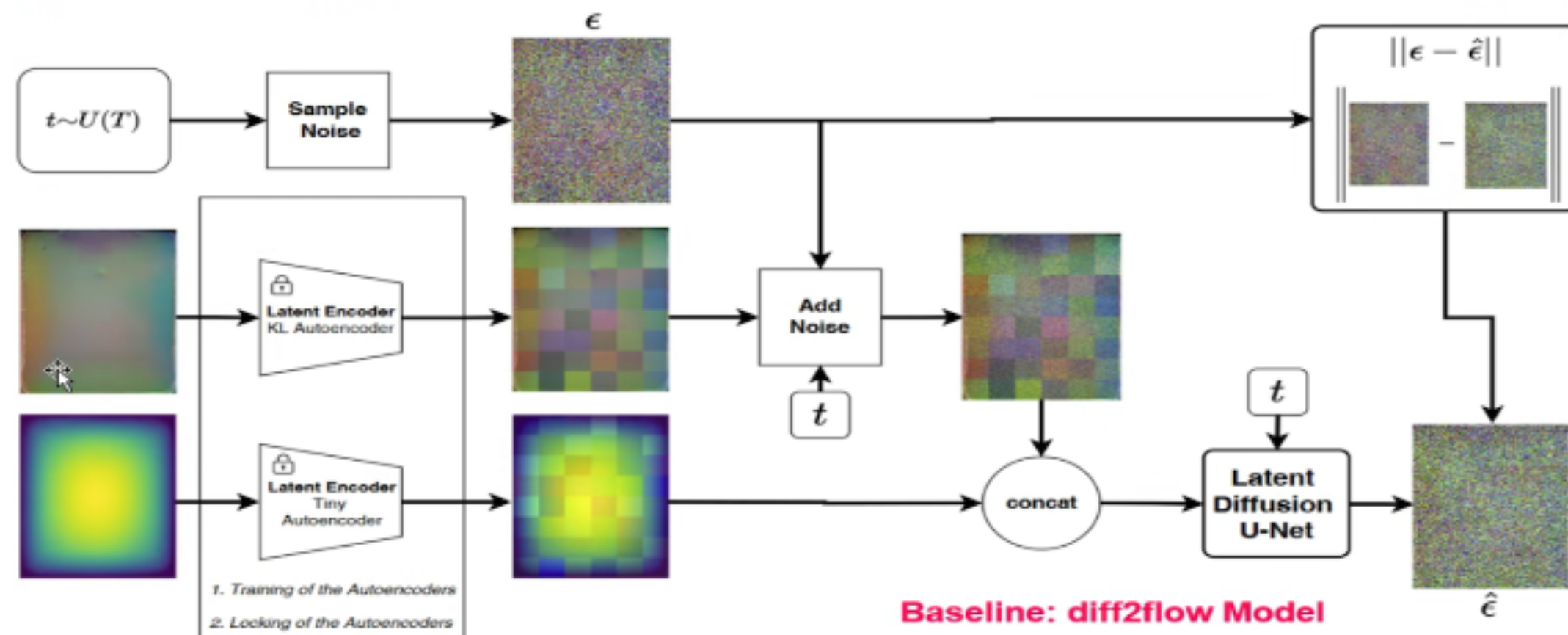

Surface Mount Production Line



Surface Mount Production Line

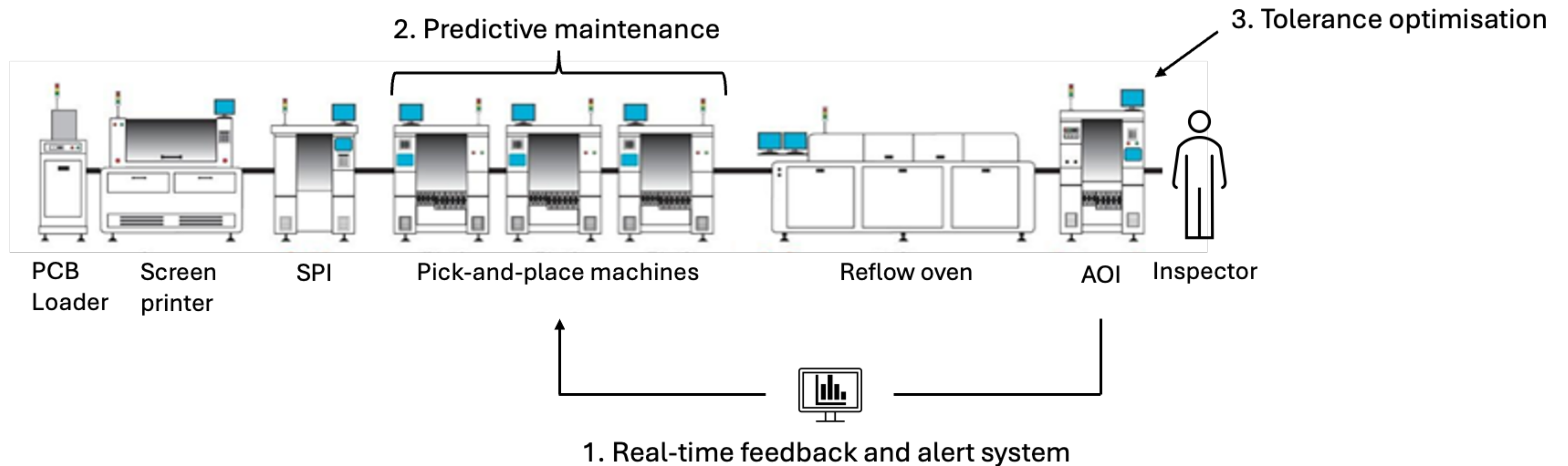

SPI – Solder Paste Inspection

AOI – Automated Optical Inspection

AOI – Automated Optical Inspection

Surface Mount Production Line

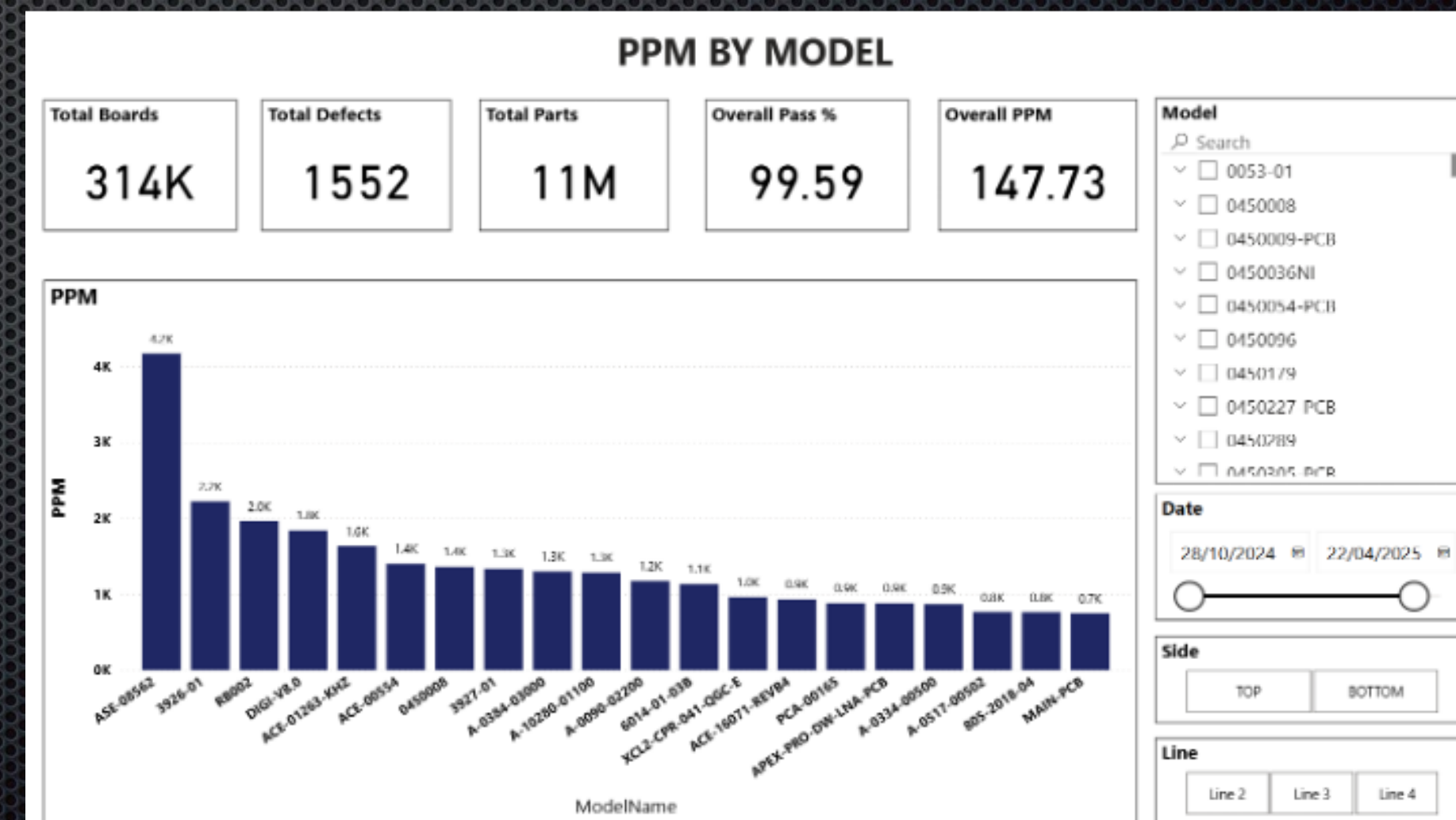
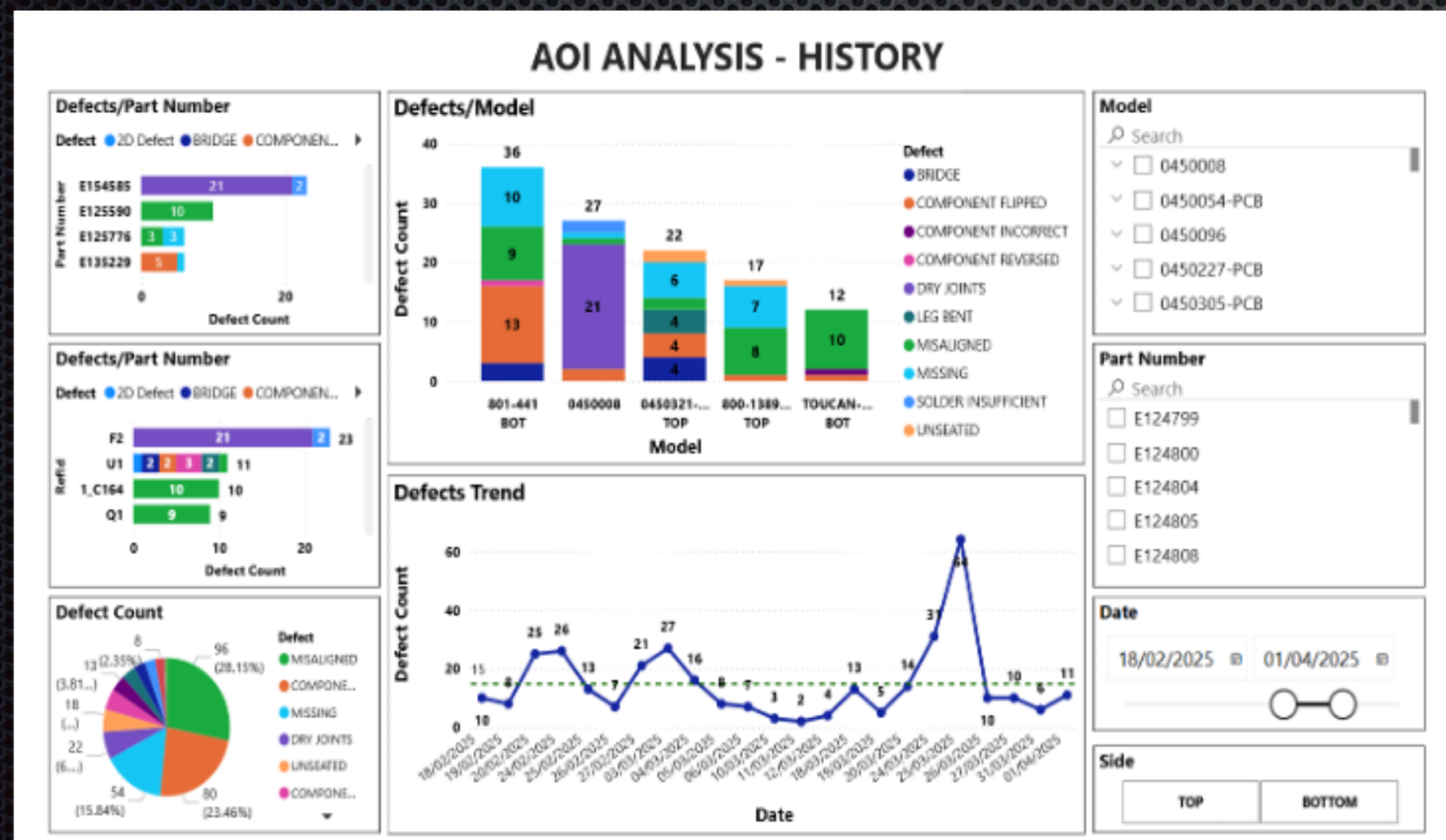
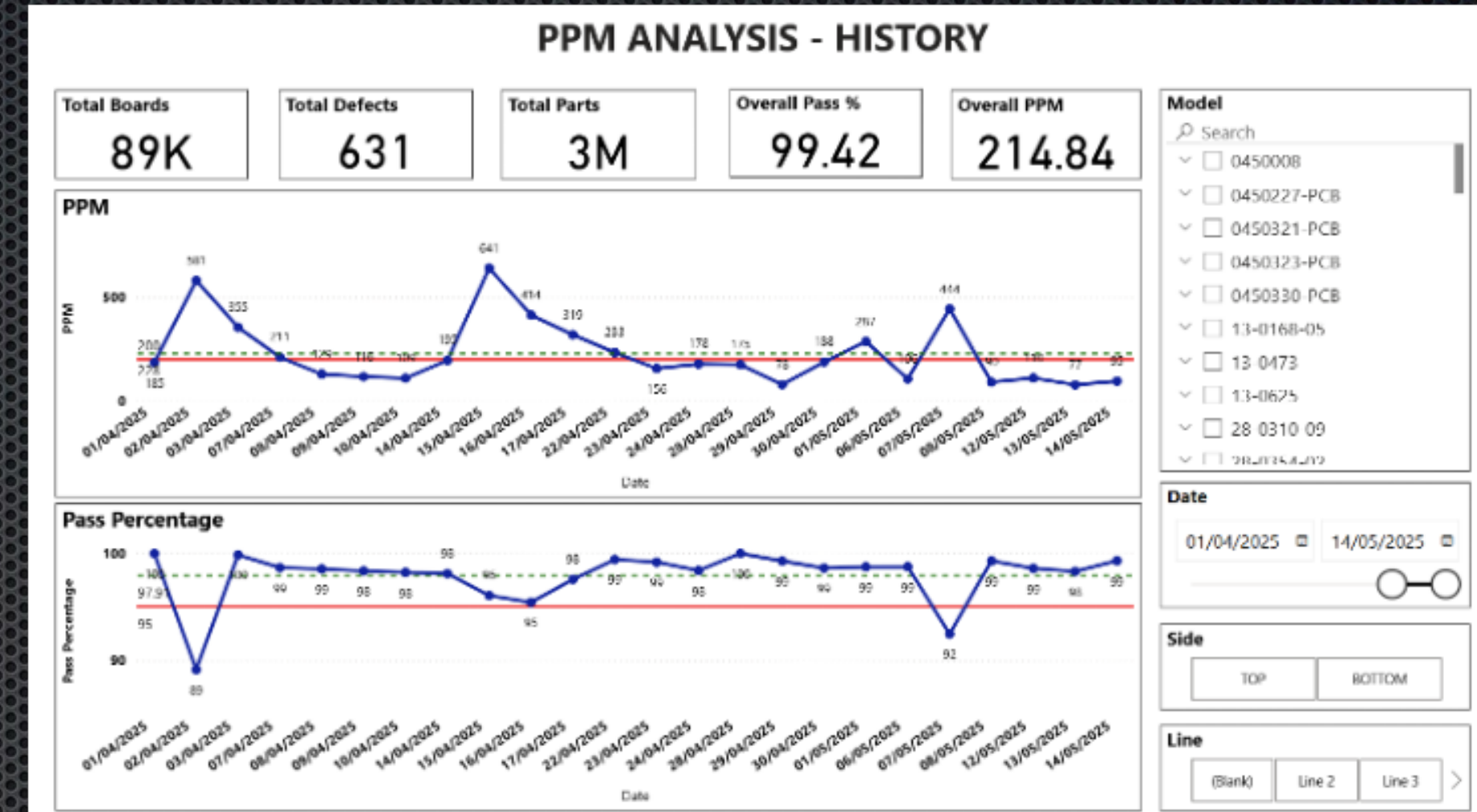
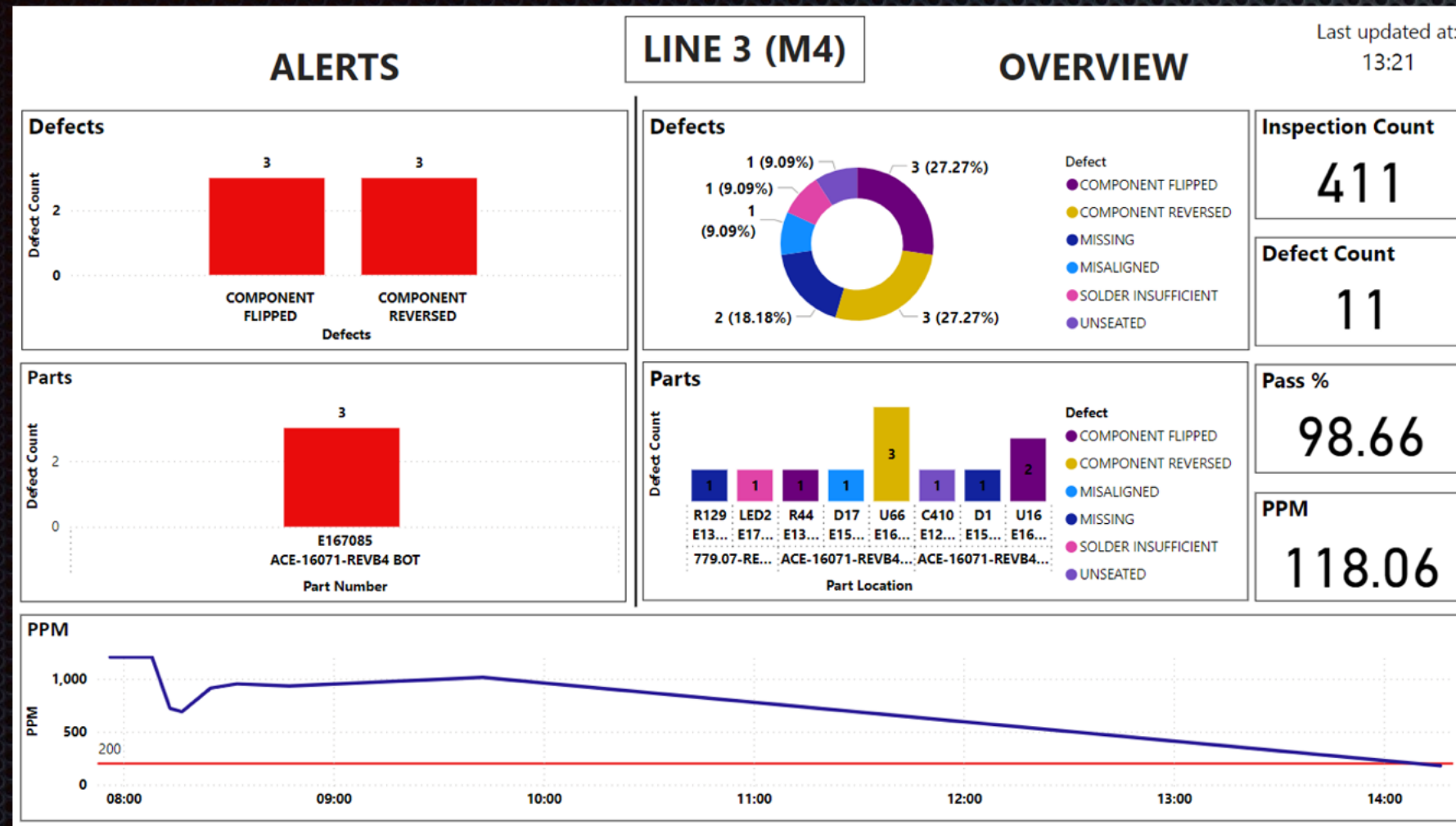

Surface Mount Production Line



Digital Twinning for Predictive Maintenance of Turret System

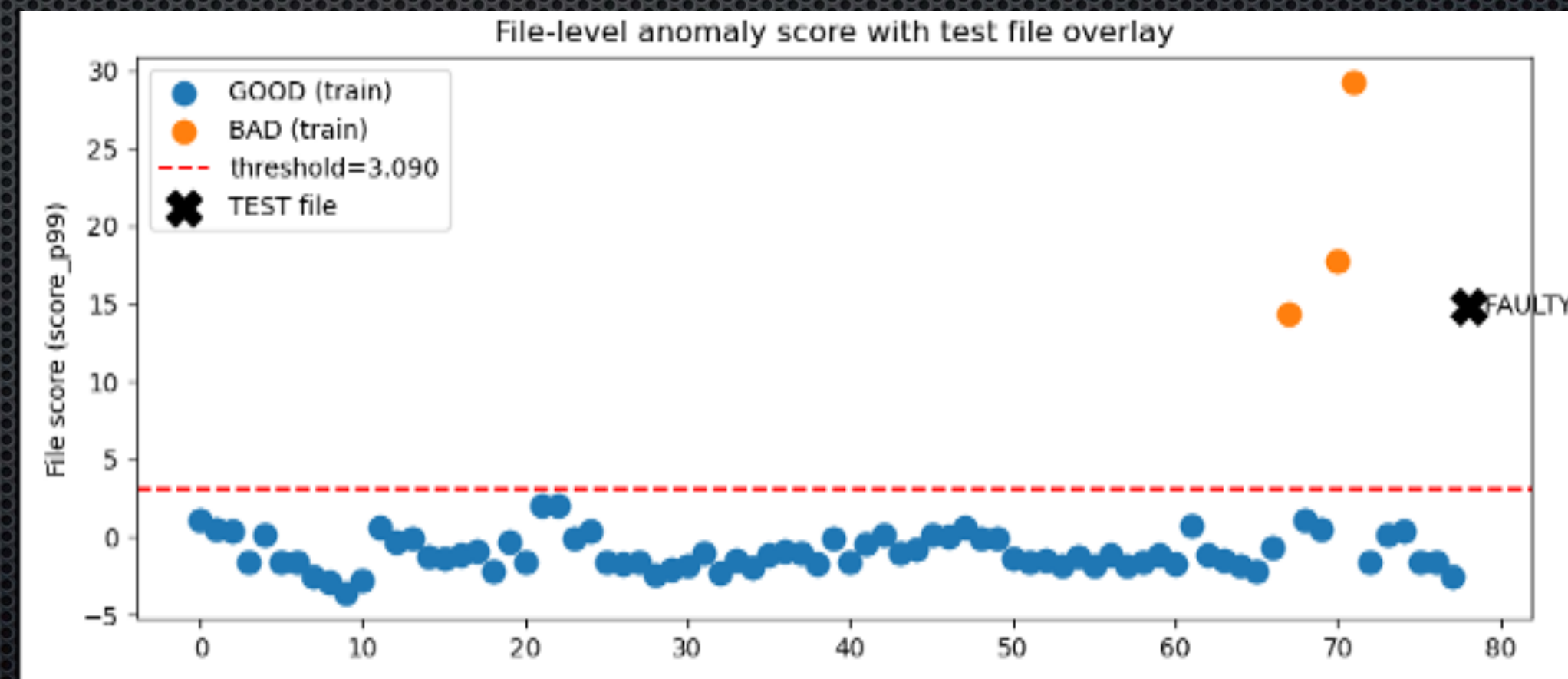
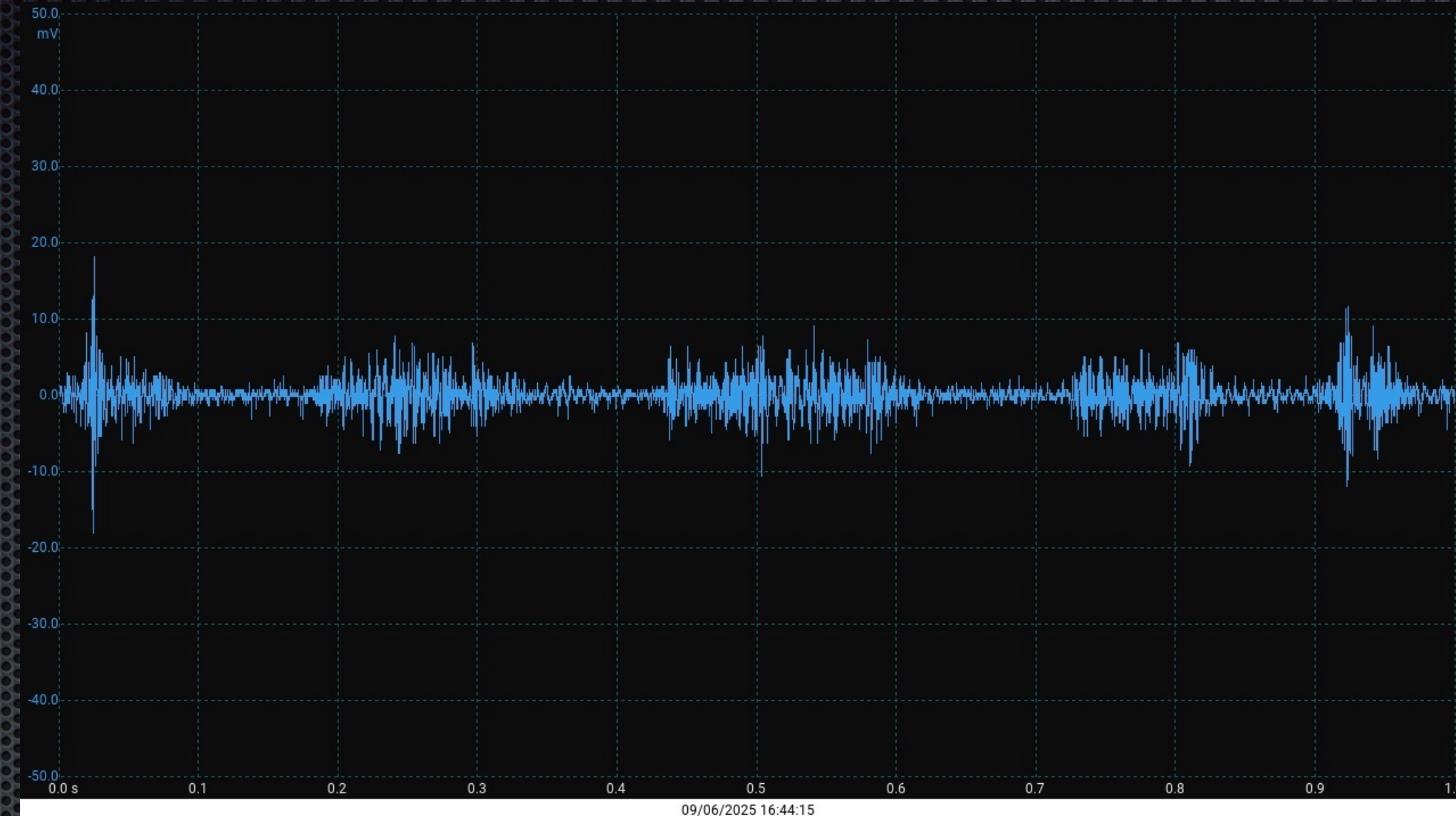

Total Cost Saved (1 Line) > £80k per yr

Tech to be deployed to other Elite sites.

Automated Transportation of Solid Assay Reagents using Parallel Robotics and Machine Vision QC in a Humidity Controlled Environment

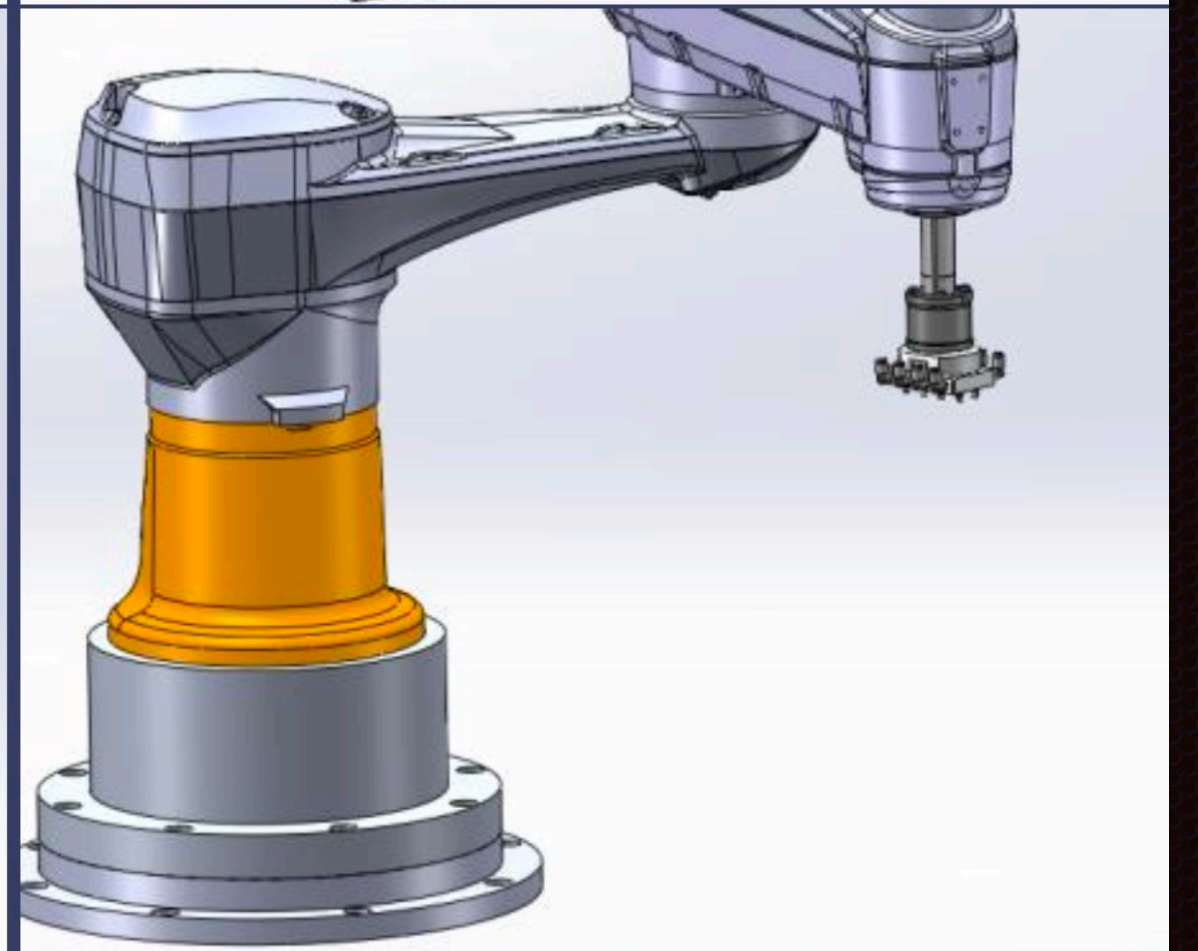
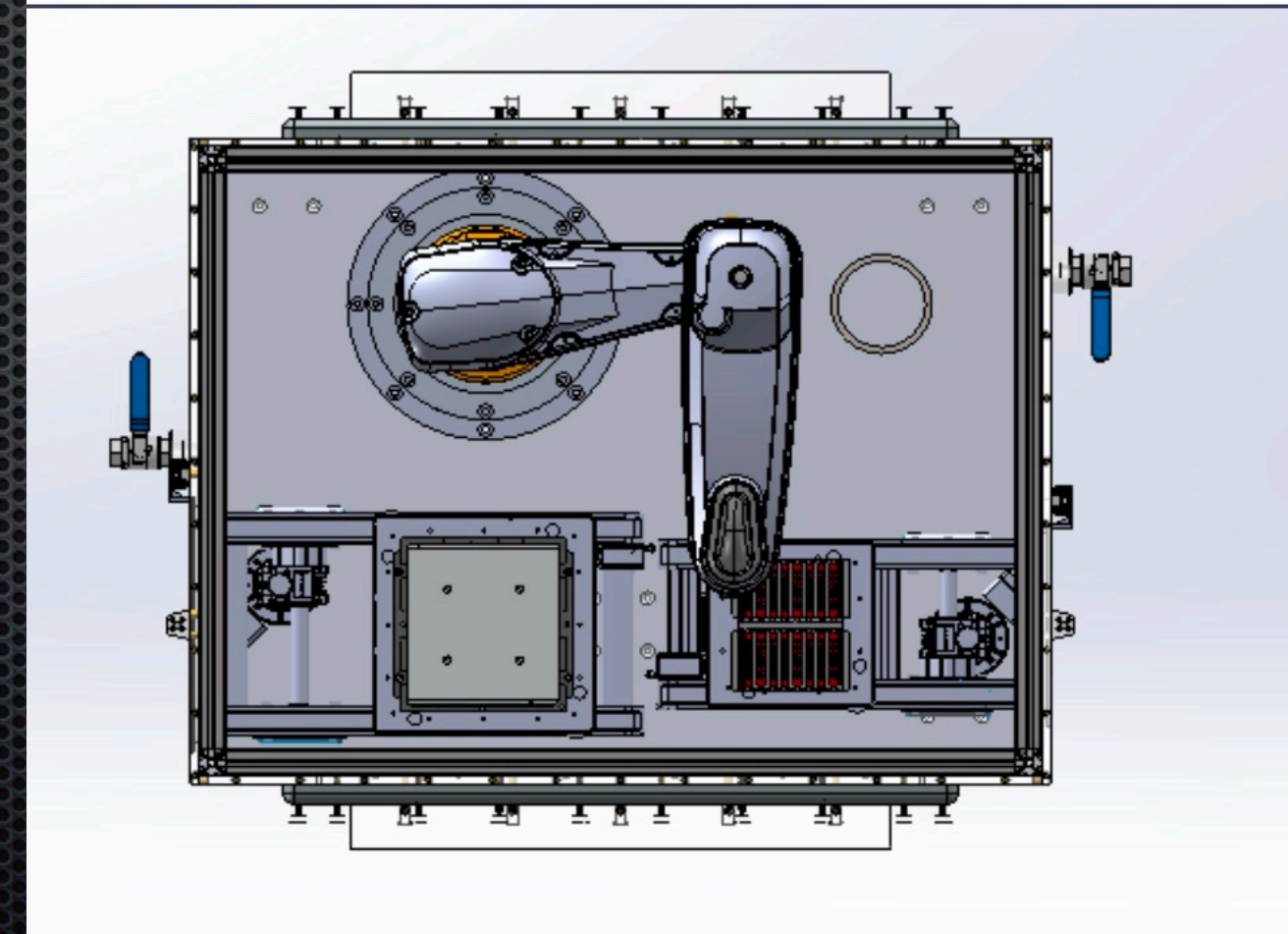
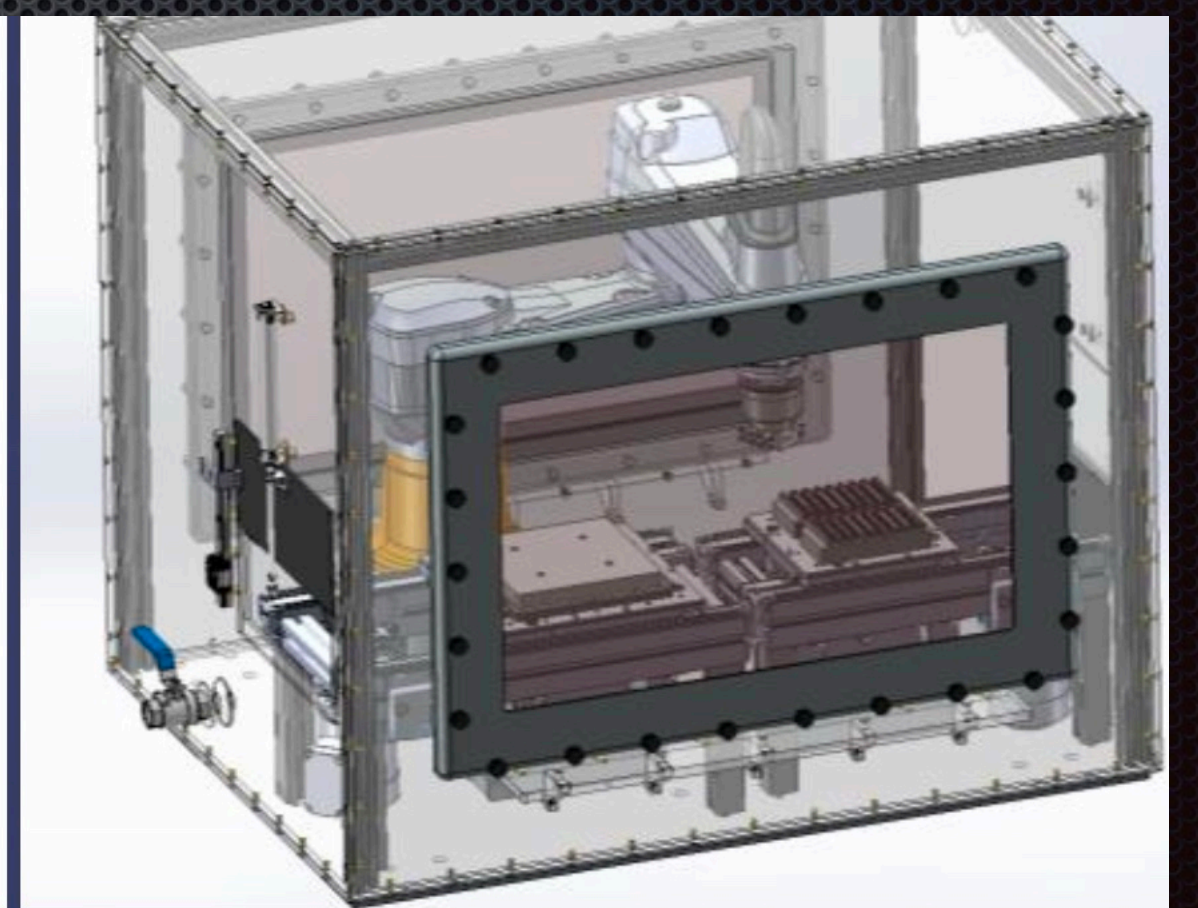
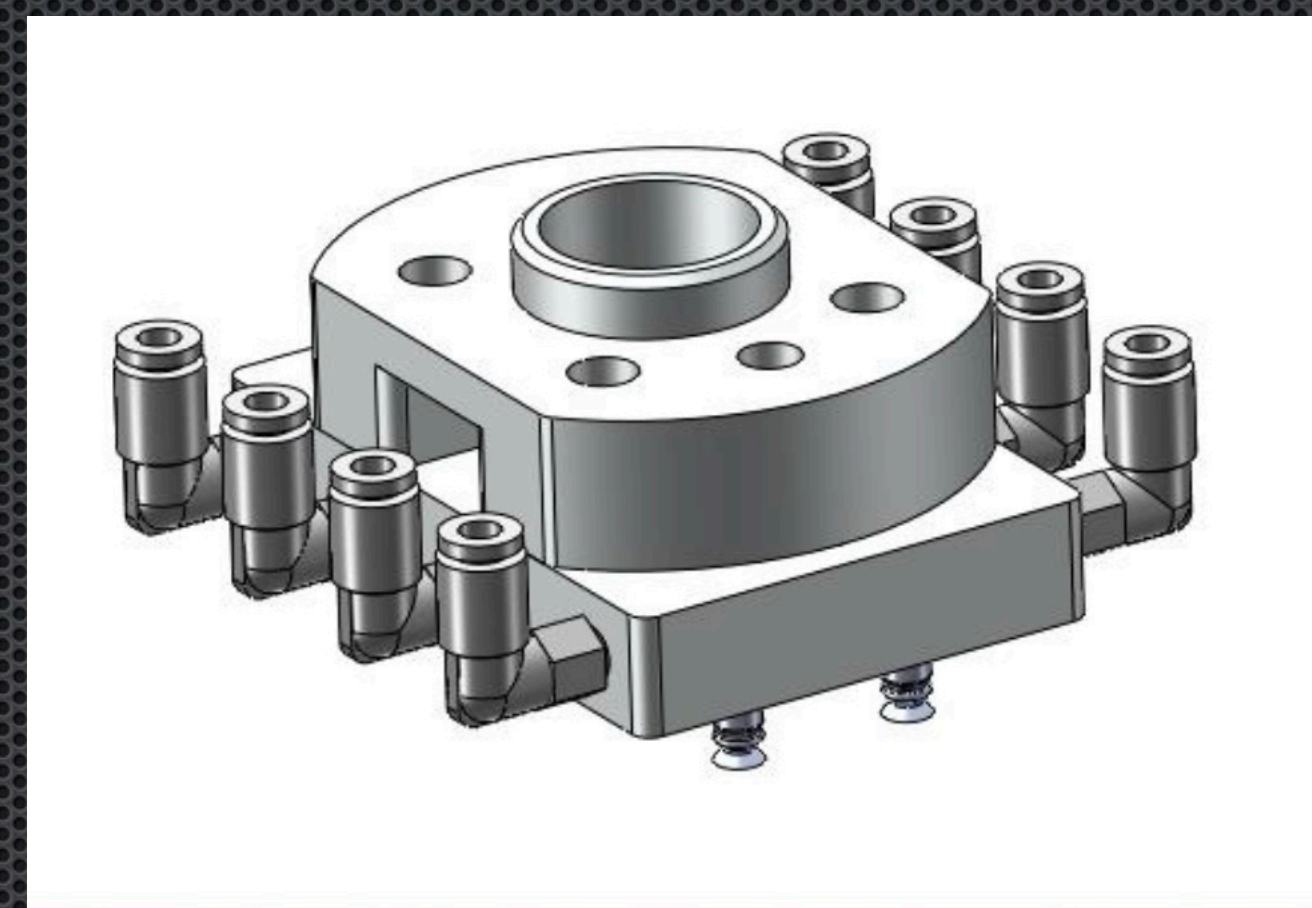
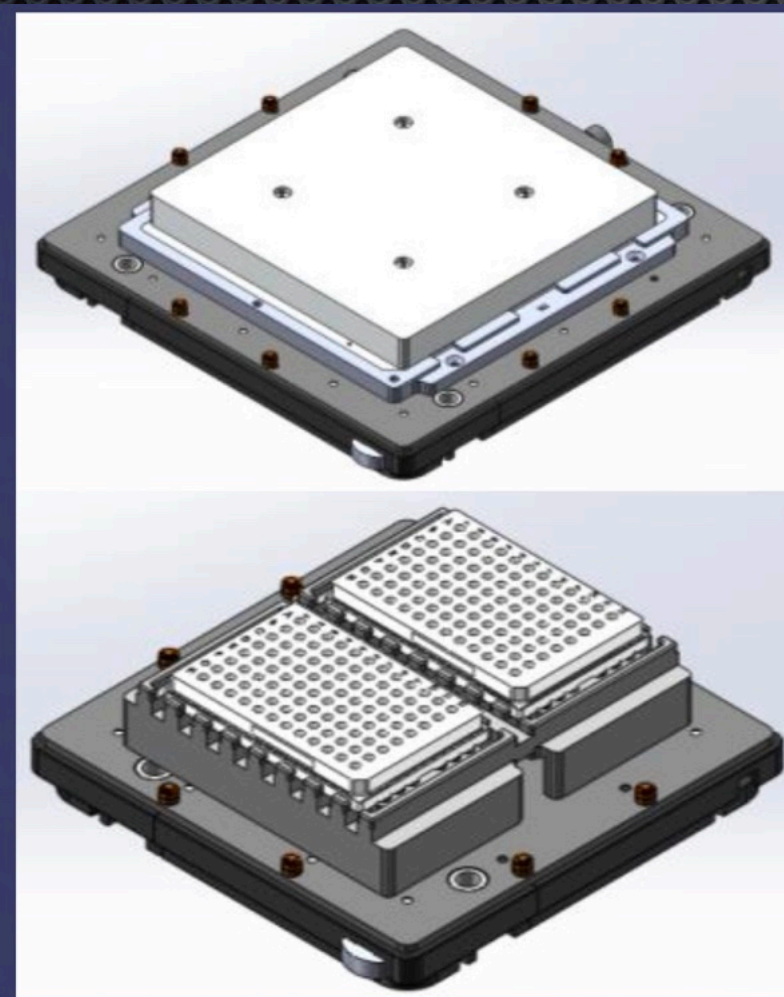
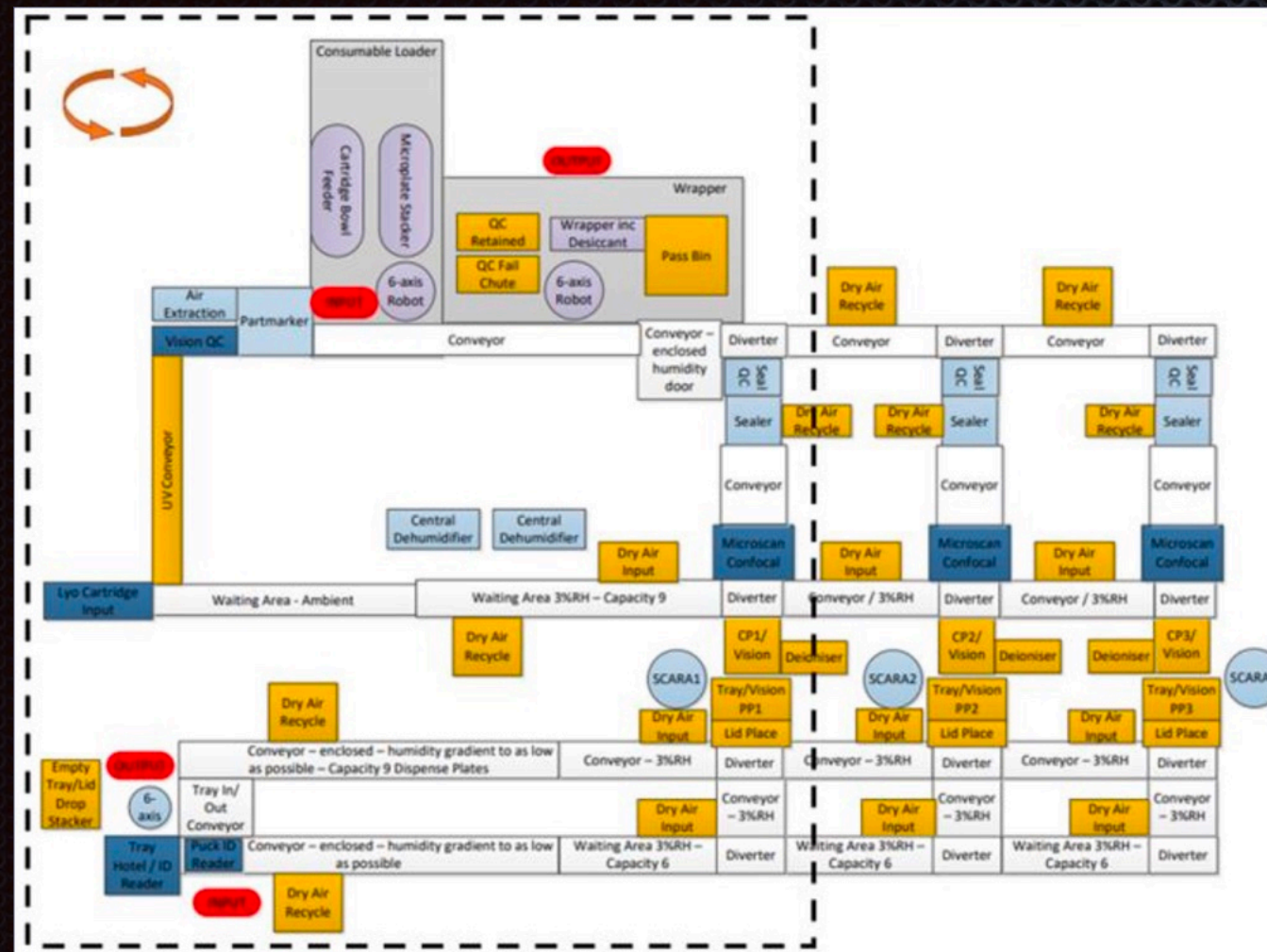

MAvRIC

Multi-Agent and Advanced
Robotics Centre

Main Centrepiece

- 2x ER-FLEX Systems
 - UR5e robotic arms mounted on MiR250 AGVs
 - Arm payload \approx 5 kg
 - Vehicle payload \approx 180 kg
 - Operation time up to 5 hours between charging
 - Automation in manufacturing and digital twinning
 - Automate lab/hospital tasks to limit human presence and reduce risk of contamination
 - Home assistance



Main Centrepiece

- 1st HEI on Island of Ireland to utilise **Collaborative Robots (Cobot) + Autonomous Mobile Robots (AMRs) Combo** for Research and Teaching*



*As of January 2026

Key Equipment

- 4x Turtlebot4
 - Multi-sensor equipped AMRs
 - Max. payload \approx 9 kg
 - Operation time: Up to 4 hours
 - LiDAR and depth camera



Key Equipment

- 3x Bambulab X1
 - Multi-Filament 3D Printers
 - 7 μ m LiDAR-assisted automatic calibration and inspection
 - CoreXY motion system
 - High-speed multicolor printing with AMS
 - Multi-material printing



Key Equipment

- 3x OrangeApps Robotic Arms
 - Mini KUKA-Compatible Robotic Systems
 - KUKA® OfficeLite, the virtual robot controller from KUKA®
 - Kinematics to mimic actual industrial robots

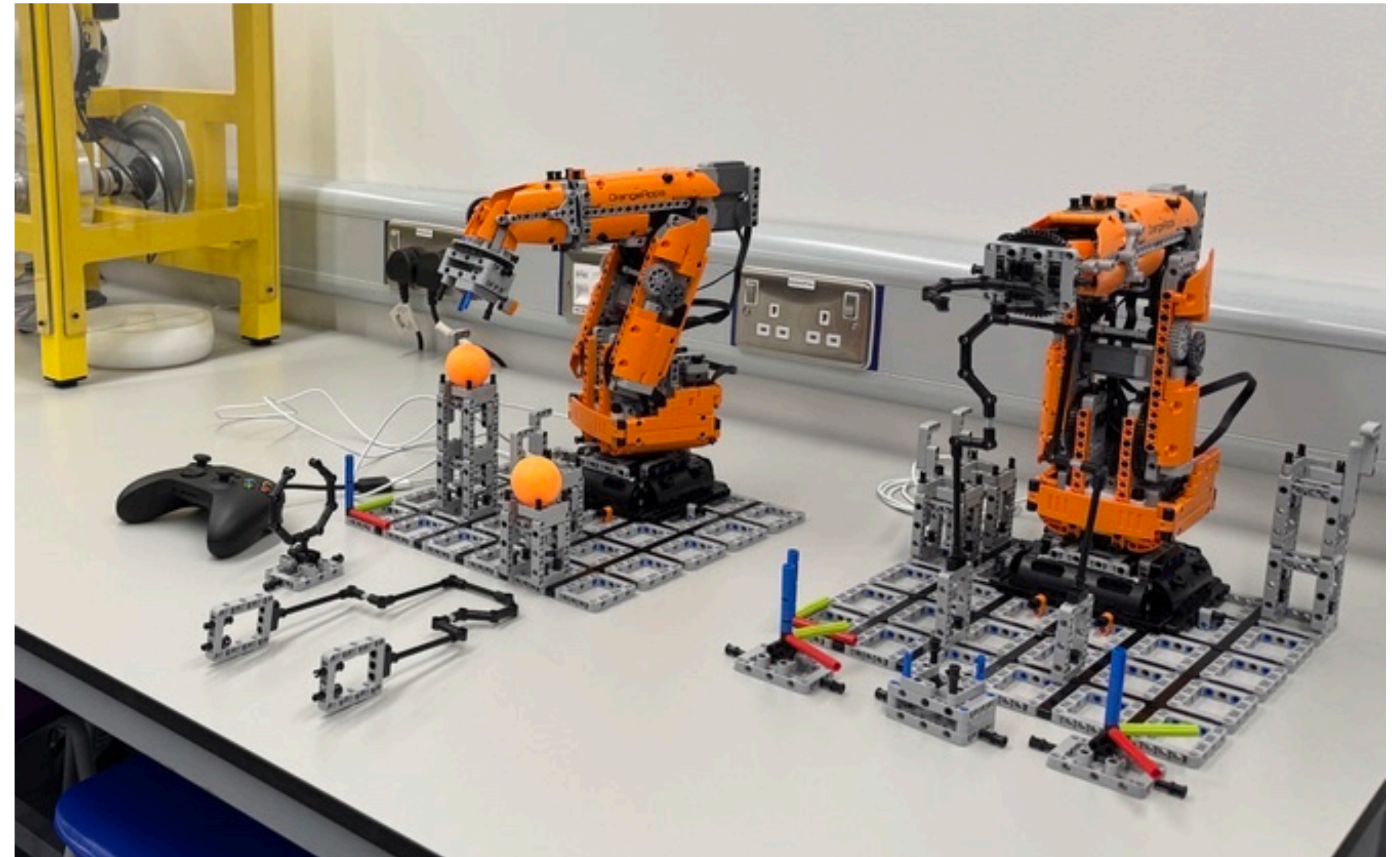

Key Equipment

- 4x MinSeg Robotic System
 - Multi-purpose advanced mini robots
 - Inverted pendulums — rockets, humanoids, etc.
 - Autonomous maneuverability
 - Real-time observation and control

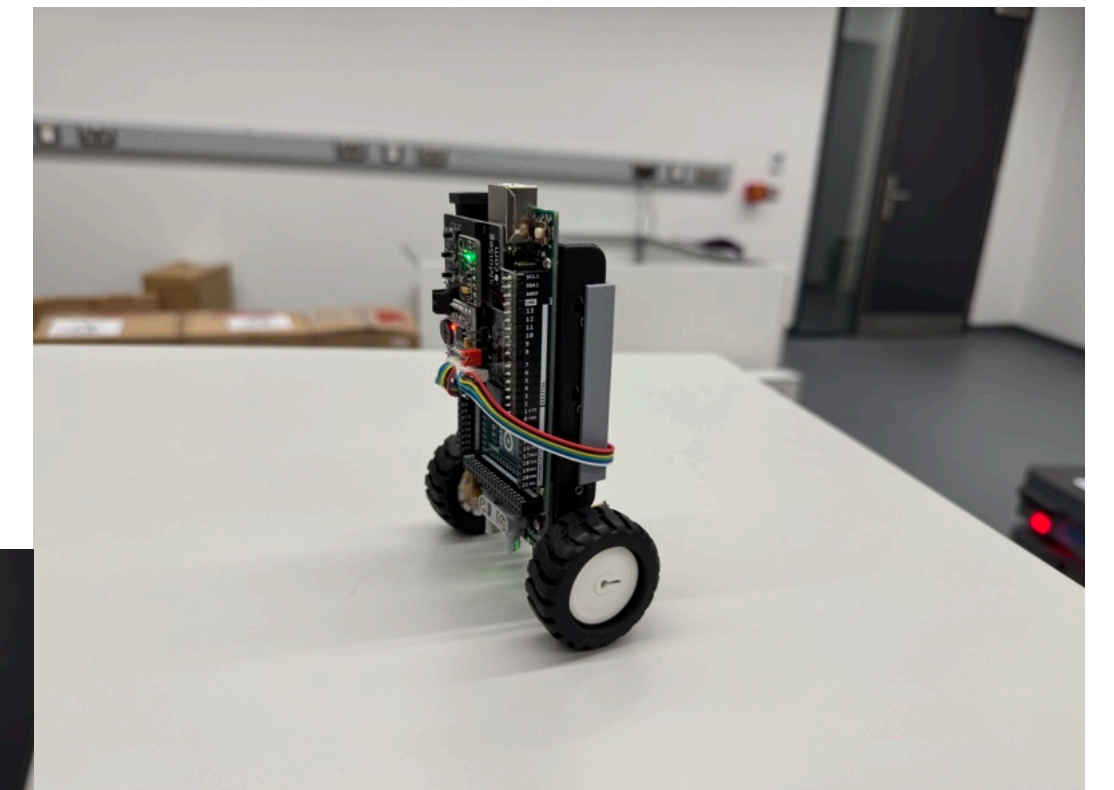

Key Equipment

- Sonotec PR 200 Combi Pulser
- Picoscope 5443D Oscilloscope
- Ultrasonic immersion and contact transducers

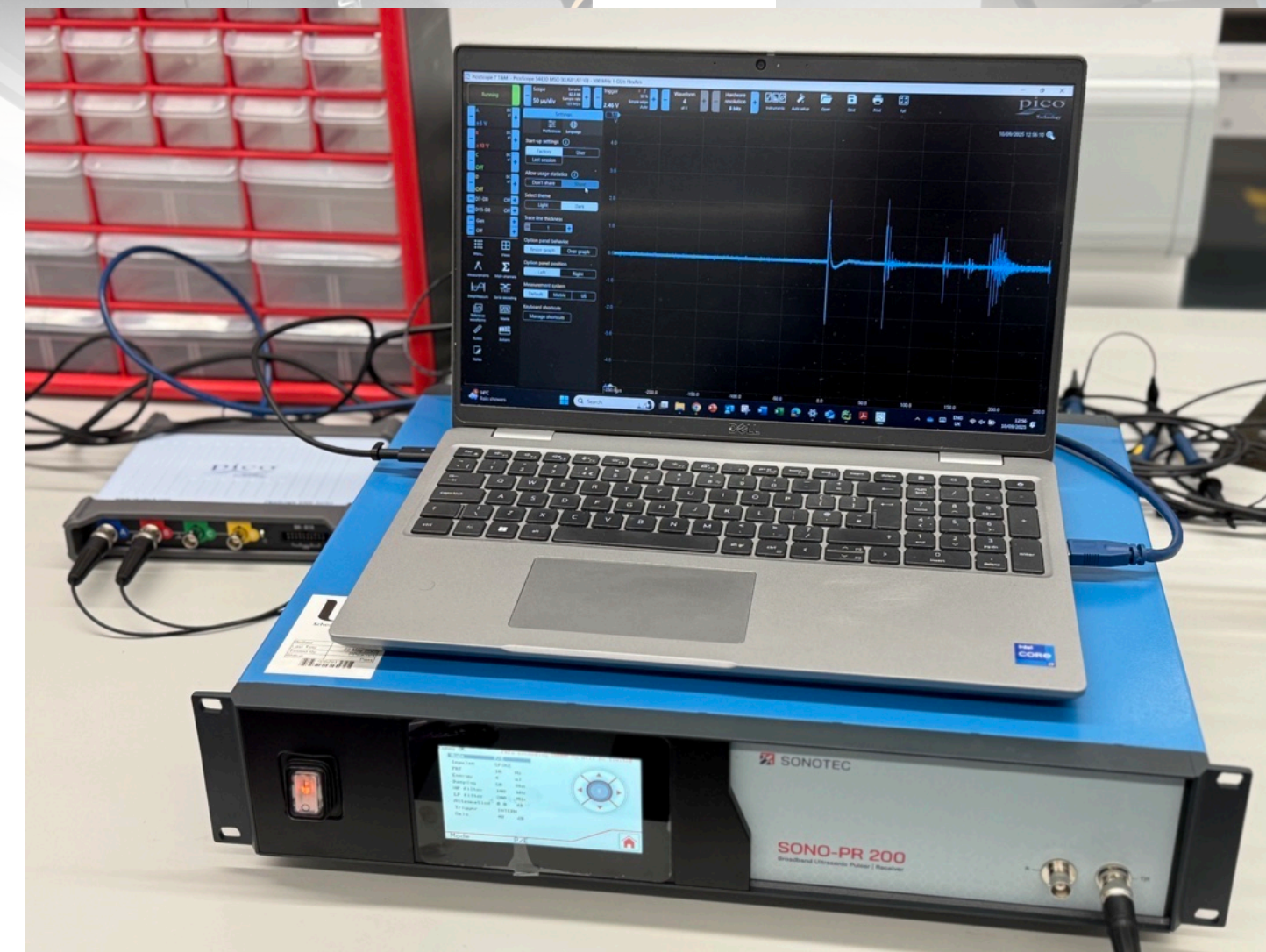
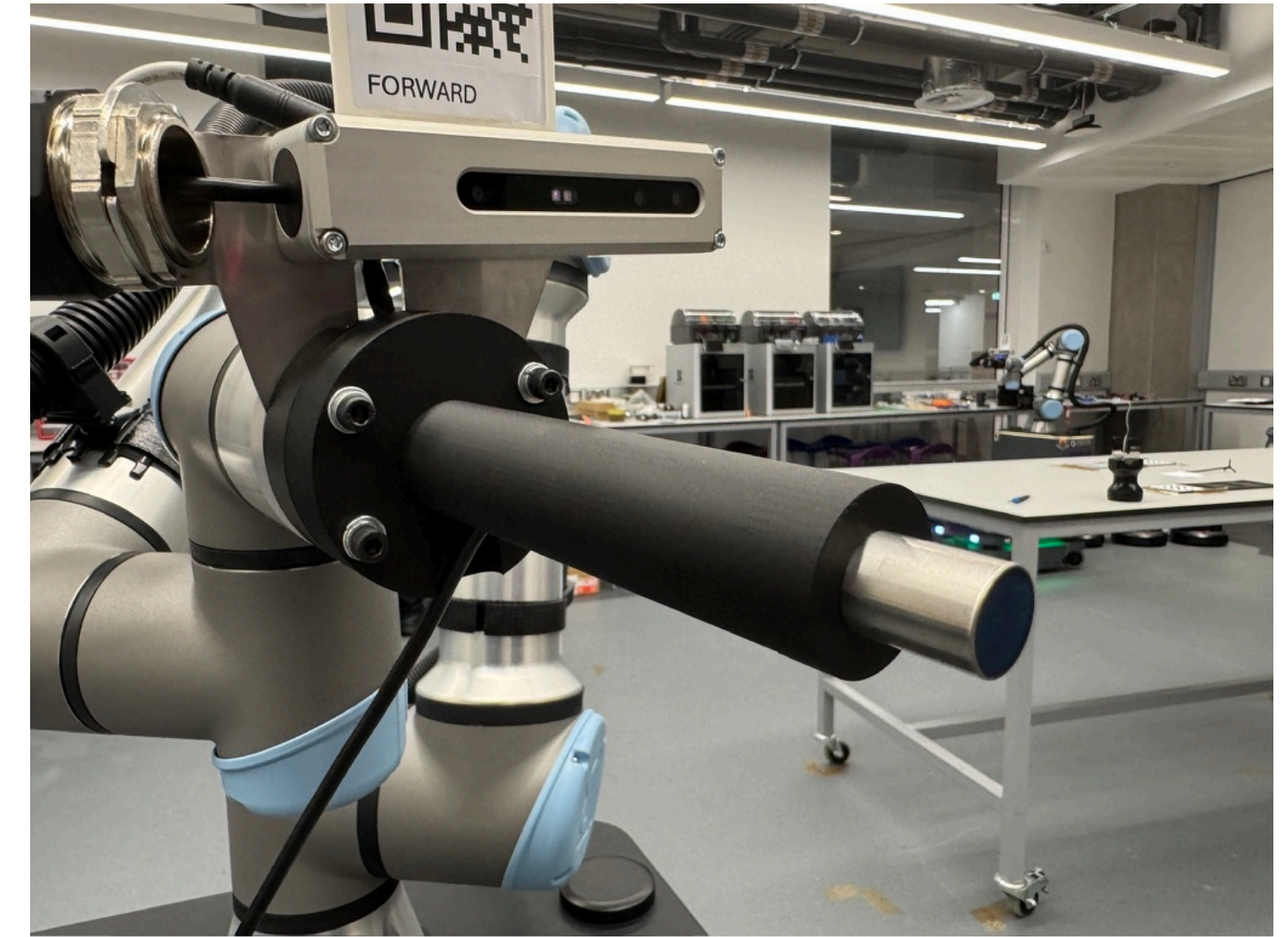
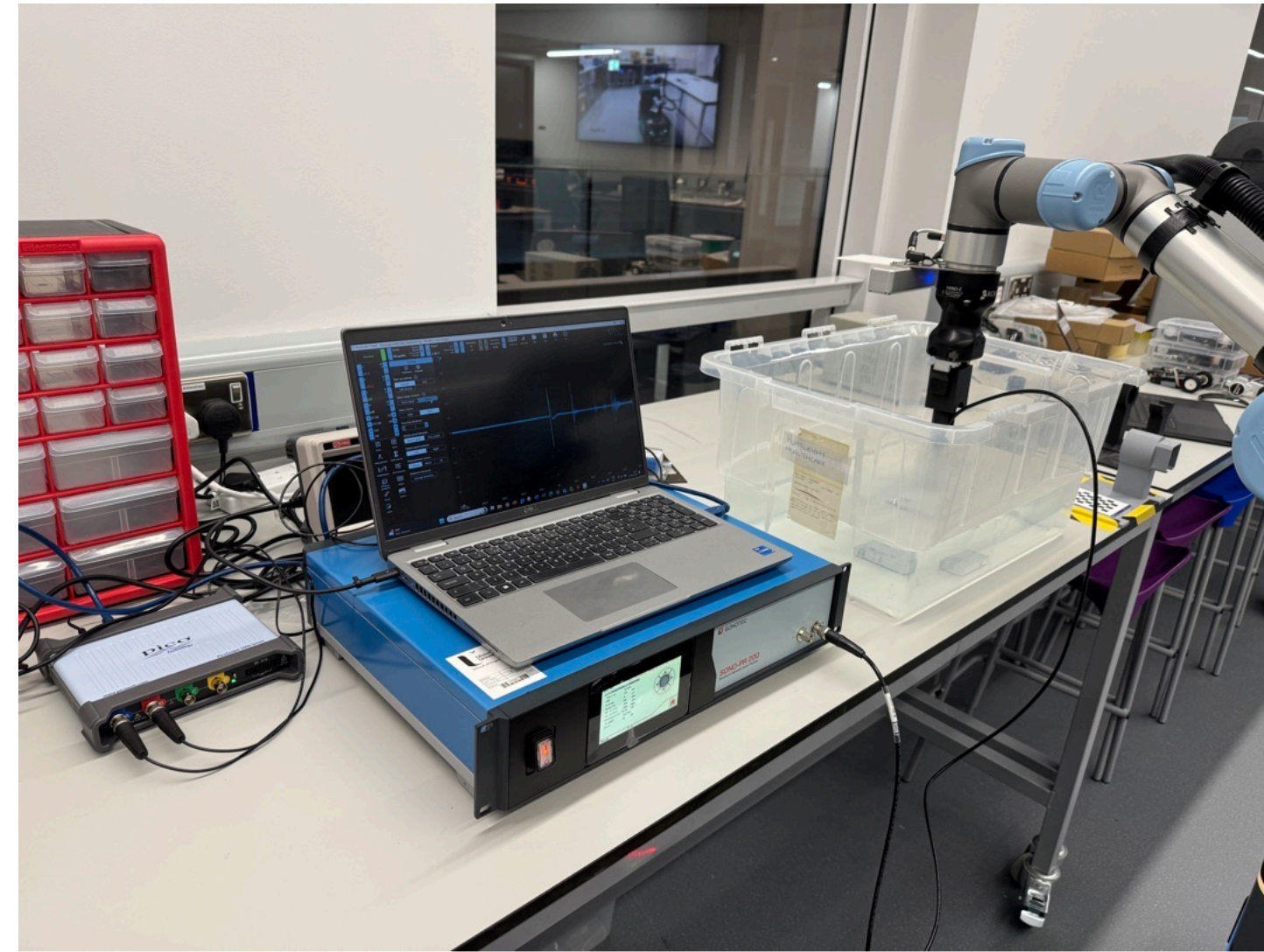

Other Existing Equipment

- Festo CP LAB
 - 6x pallet transfer system
 - 4x system trainers
 - 2x CP Bridge
 - 1x Robotino + SIM Environment
 - 2x magazine modules
 - 1x measurement module
 - 1x muscle press module
 - 1x tunnel furnace module
 - 1x output module



Other Existing Equipment

- Inteco Control Systems
 - 1x helicopter system
 - 1x ABS braking system



Key Highlights Thus Far...

- Outreach activities
- Encourage STEM in NI and ROI
- Produce future talents and tech-equipped workforce
- UCAS Open Day 2025
- East Belfast Summer School 2025



UCAS Open Day 2025

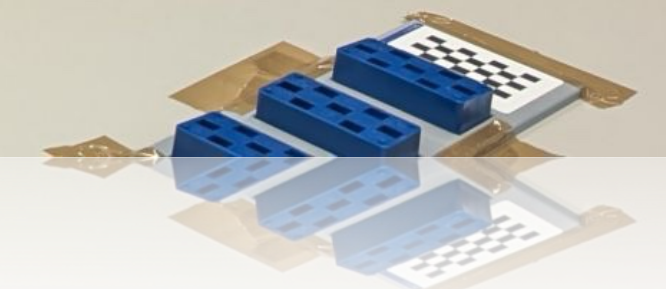

Key Highlights Thus Far...

- Hosted 2 exchange students (Czechia) via **EU Erasmus+ Traineeship Programme** (June–August 2025)
- Hosting 1 exchange student (France) (June–August 2026)

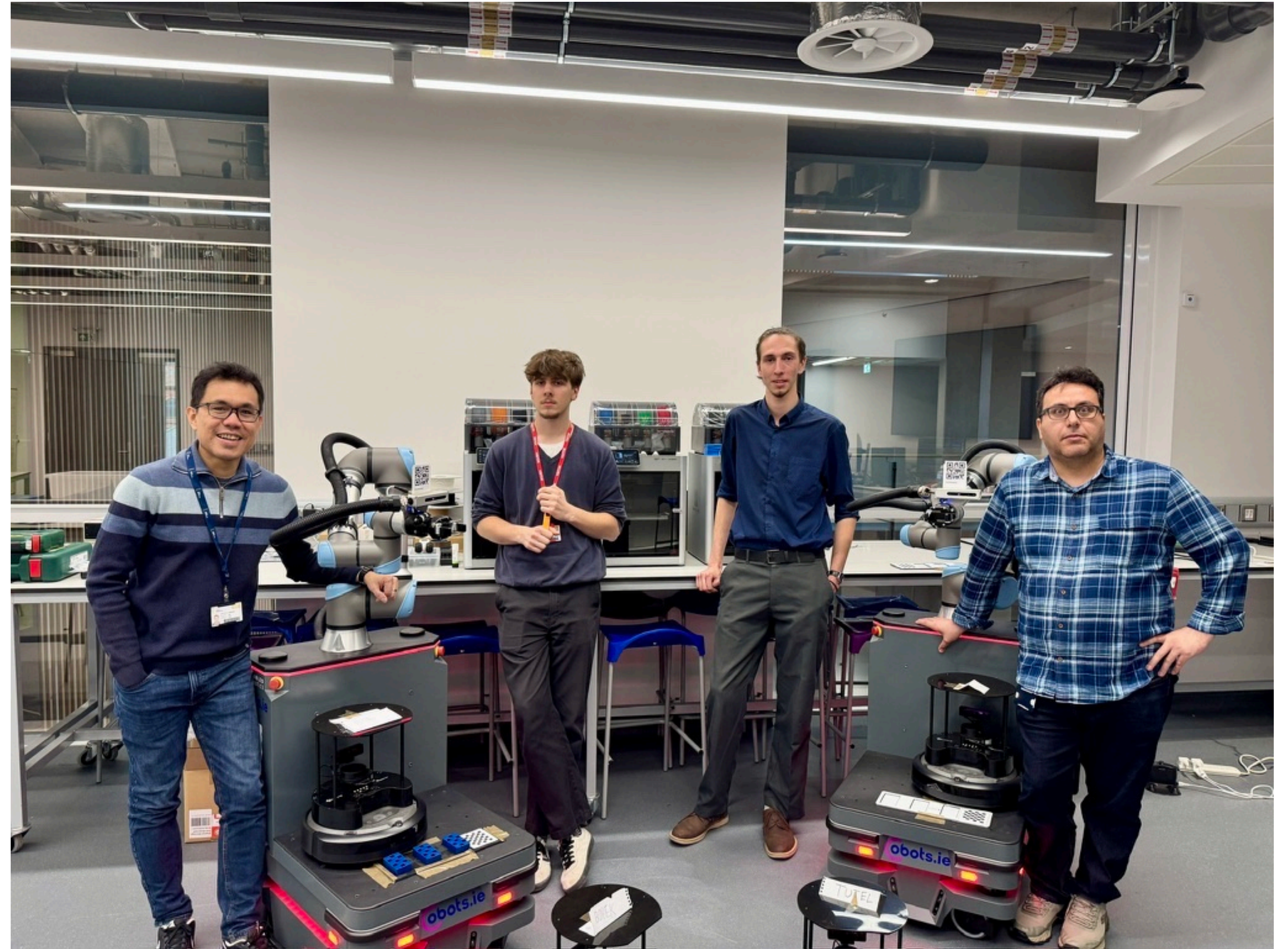

Key Achievements Thus Far...

- Further enhanced existing collaboration with **TTZ @ Nördlingen, Germany**
 - Joint PhD supervision
 - Multiple publications and organisation of conferences
 - Horizon EU

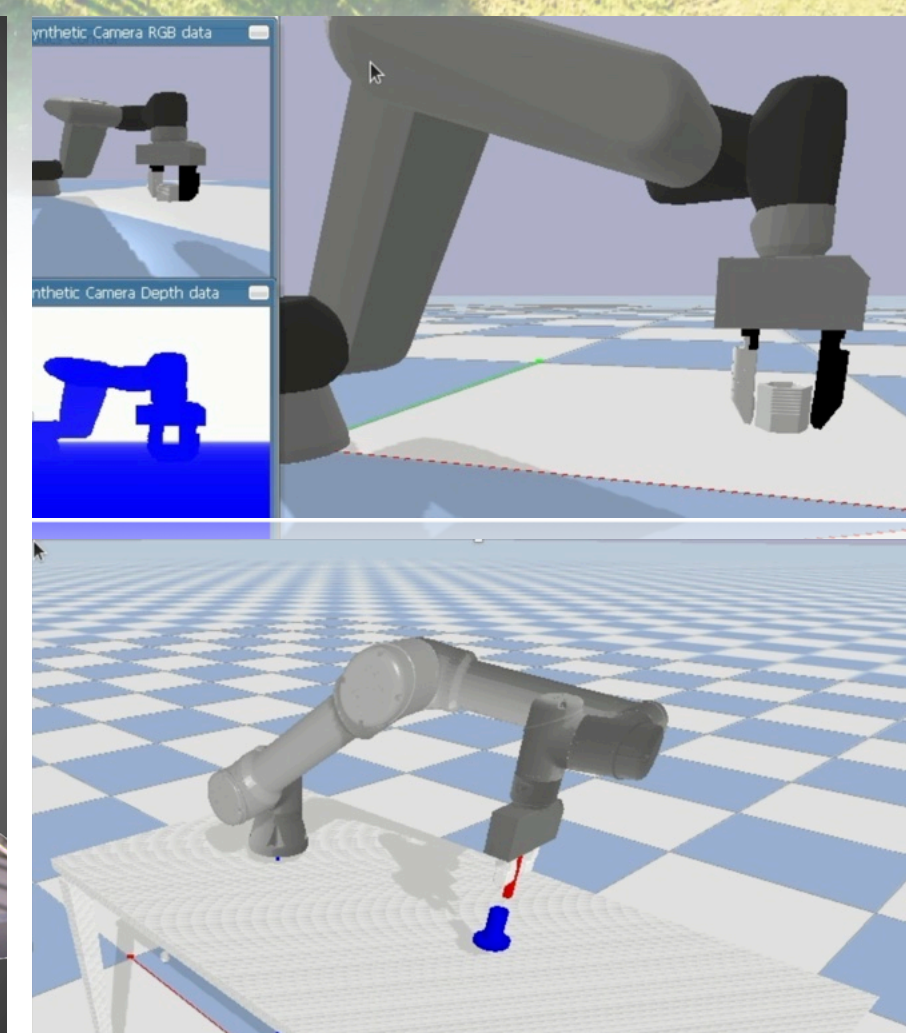
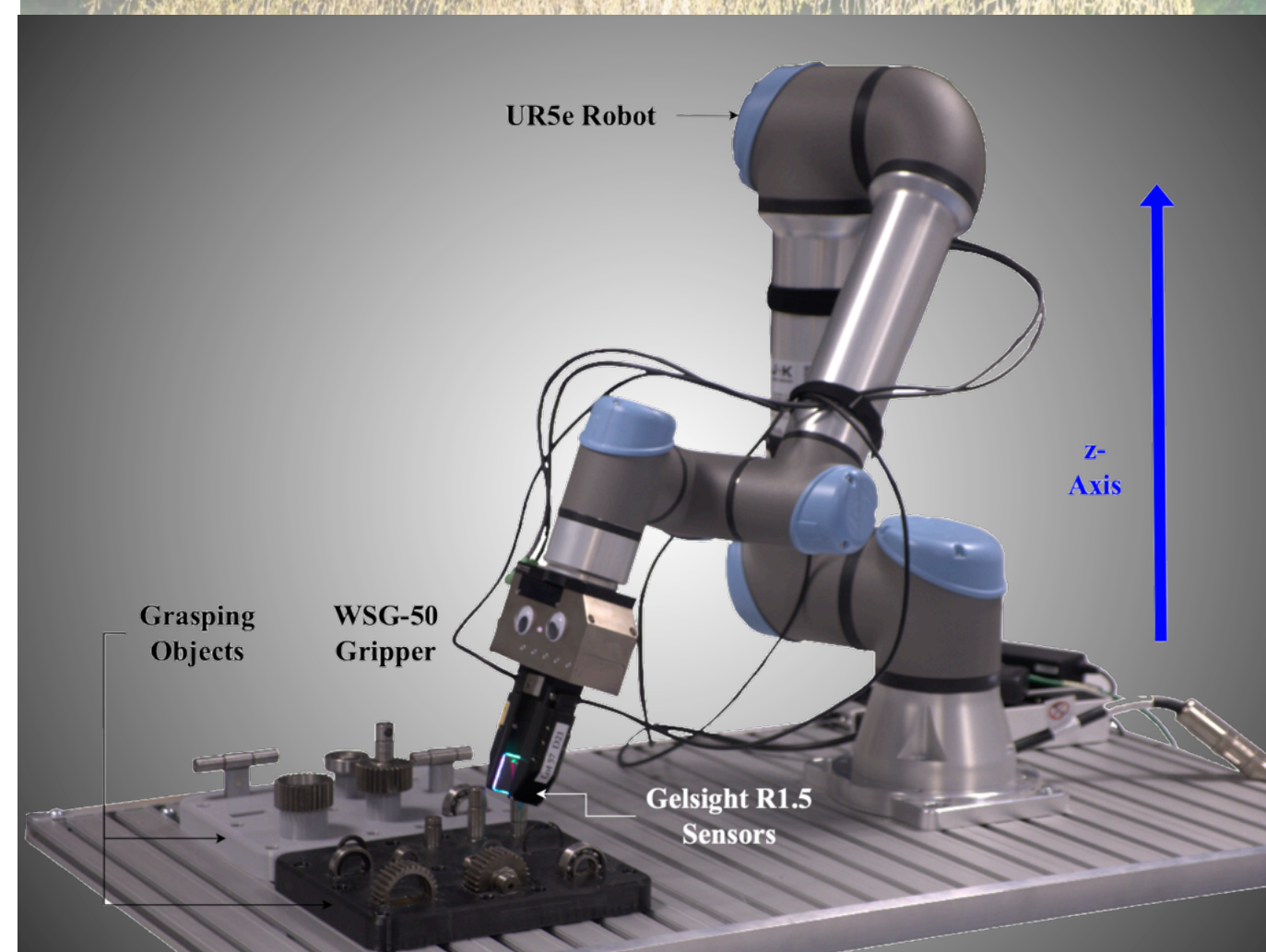
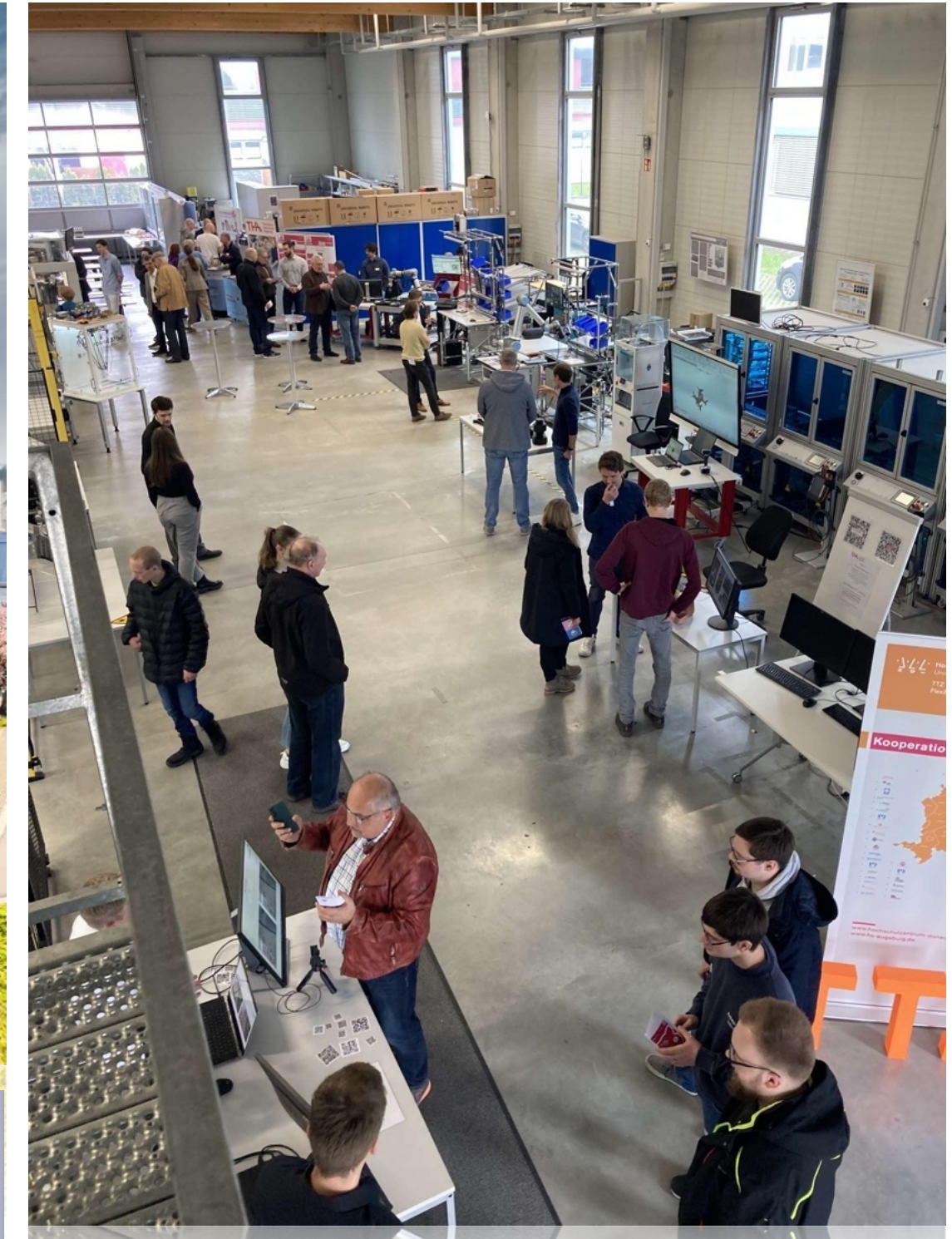

Key Highlights Thus Far...

- **DfT** showcased and featured research from the lab at the **OECD Int. Transport Forum (21–23 May 2025)** as part of current UK research related to transport digital twinning

Digital Twin of a Turbocharged Spark-Ignited Engine System for Control and Fault Diagnosis

Dr Mark Ng SMIEEE
 Reader, School of Engineering, Ulster University, UK
 Vice-Chair, IEEE Control Systems Society (UK & Ireland Chapter)
 ILN+ Researcher in Residence with Digital Catapult, UK



Research Website

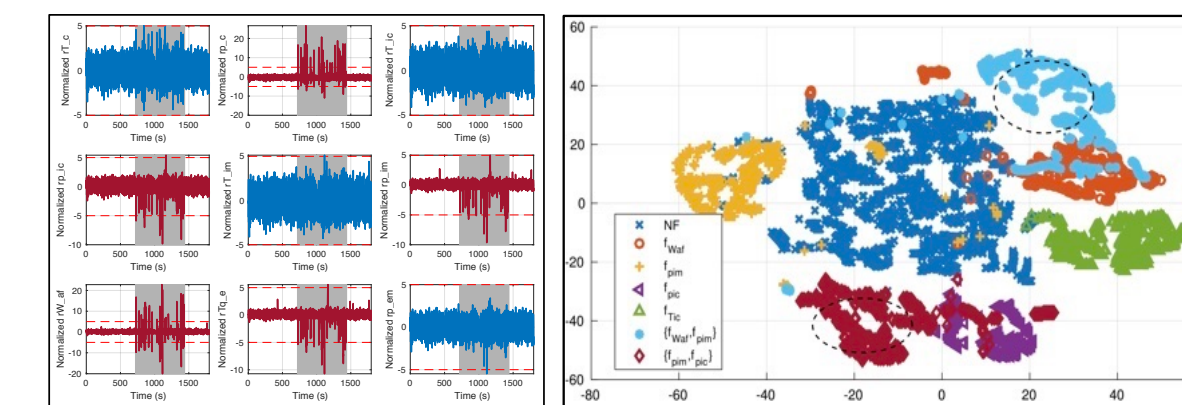
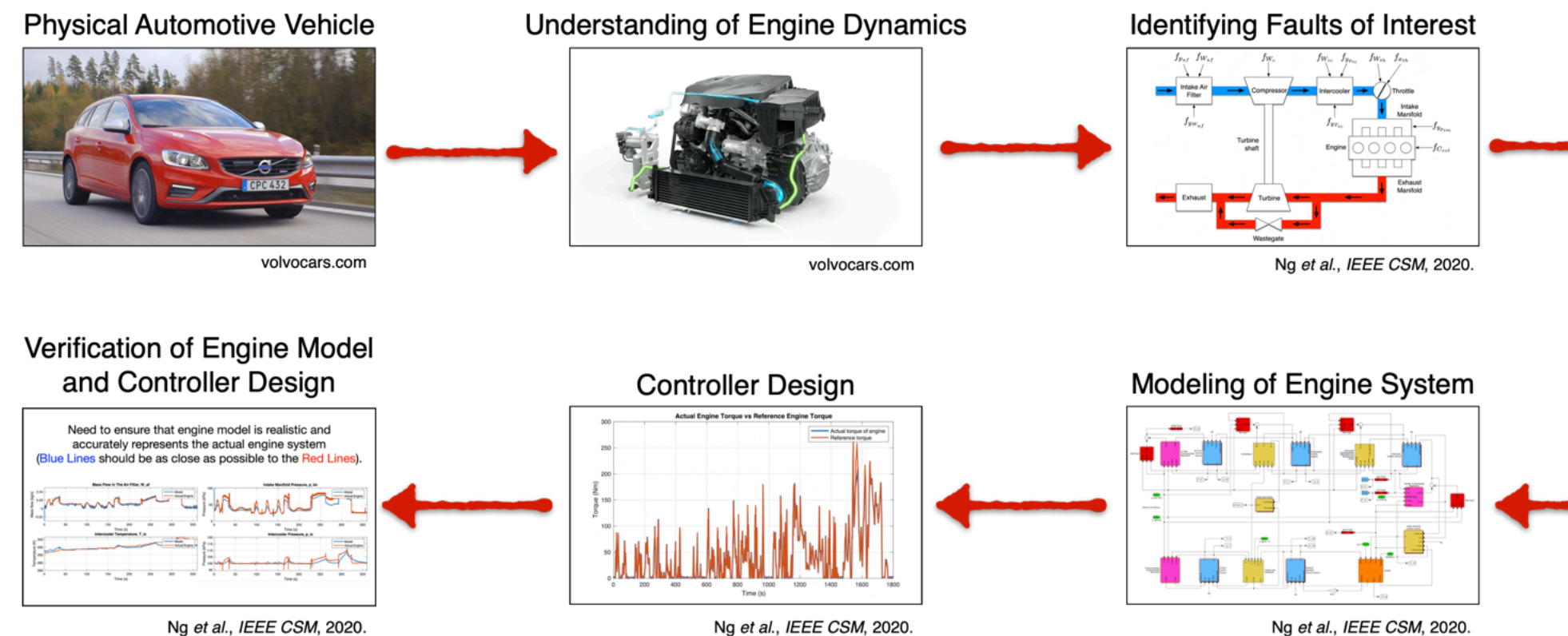

Residuals Analysis Multidimensional Data Analysis



Simulation GUI and Telemetry Visualizations

Confusion Chart (Gaussian)

True Class \ Predicted Class	Fault-free	fCvol	fWaf	fWc	fWic	fWth	fpafl	ftxh	fyTic	fyWaf	typic	typim	
Fault-free	1000												
fCvol		1000											
fWaf			911										
fWc				1000	447								
fWic						121							
fWth							1000						
fpafl								715					
ftxh									919				
fyTic										988			
fyWaf											1000		
typic												128	
typim													23

Classification and Diagnosis



GitHub



IEEE CSM Paper

Simulation GUI and Telemetry Visualizations

Classification and Diagnosis

Multi-Agent and Advanced Robotics Centre (MAvRiC)



MAvRiC



NISF 2026

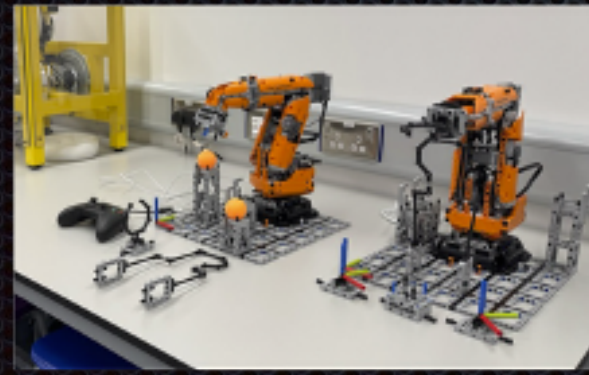
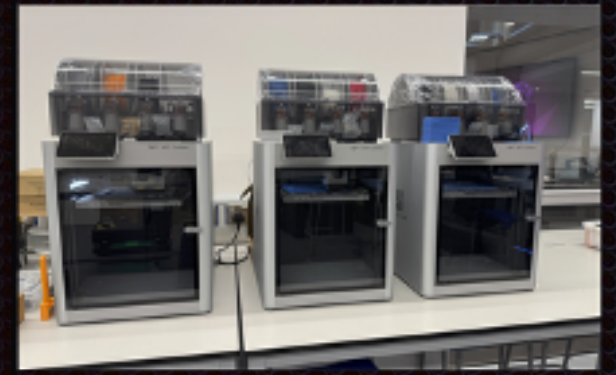
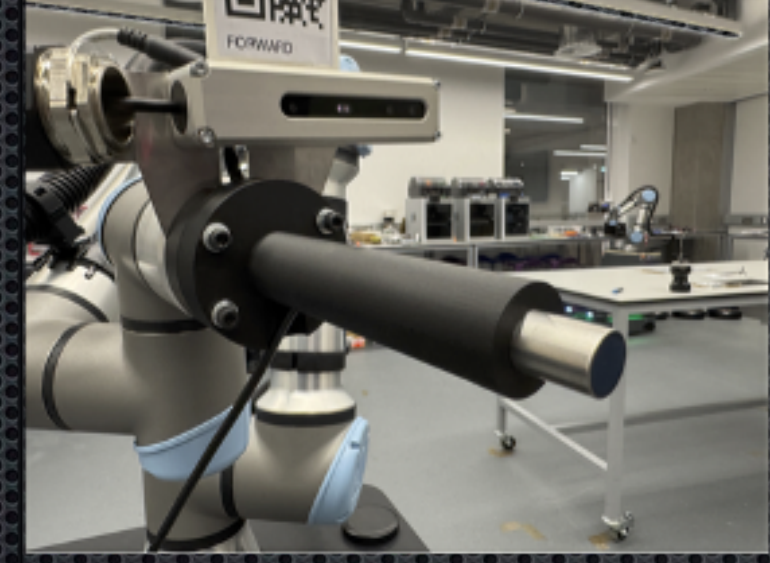
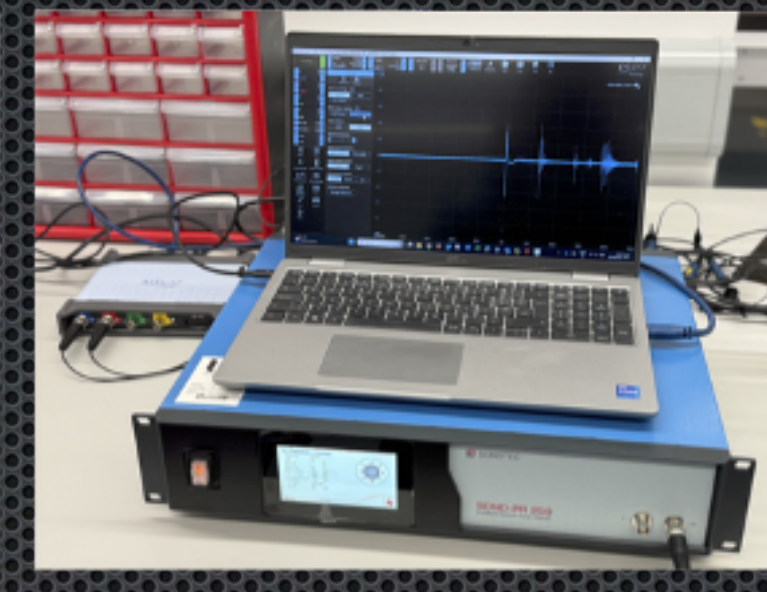
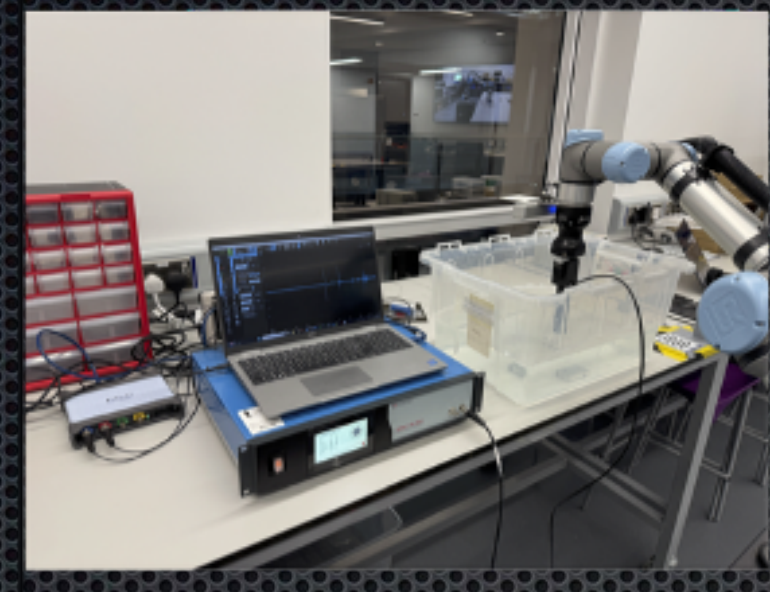
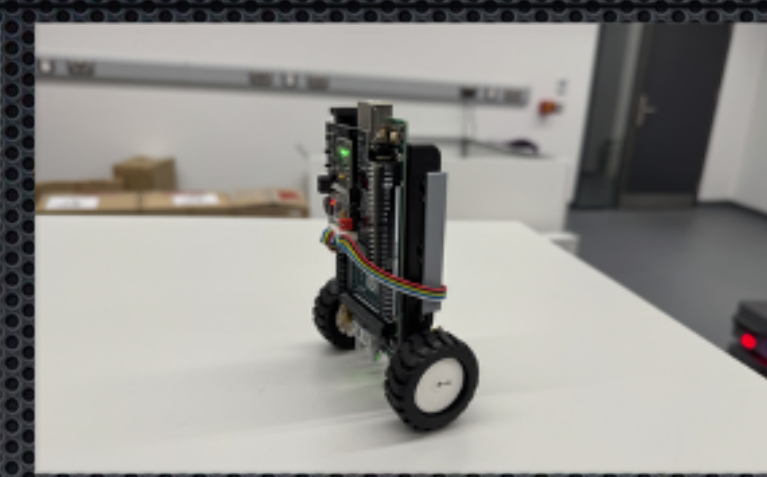

Multi-Agent and Advanced Robotics Centre (MAvRiC)





Dr Mark Ng

Control,
Fault Diagnosis,
Digital Twin



Dr Ming-Wei Chang

High precision printing,
Nanotechnology,
Controlled release,
Biomaterials, Sensors



Dr Morteza
Tabatabaeipour

Ultrasonics,
Structural integrity,
Machine Learning,
Robotics

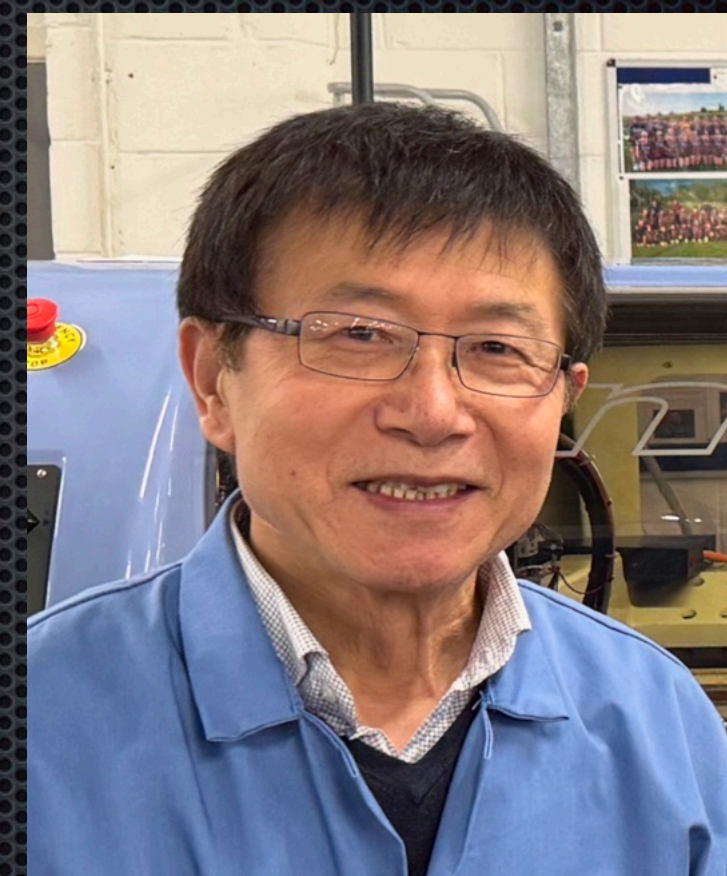

Prof. Yaxin Bi

Machine learning,
Ensemble learning,
Dempster-Shafer theory of evidence,
Data analytics,
Reinforced learning

Control Systems, Fault Diagnosis, Digital Twin, and Simulation Testbed

Physical Systems Modelling and Parameterisation

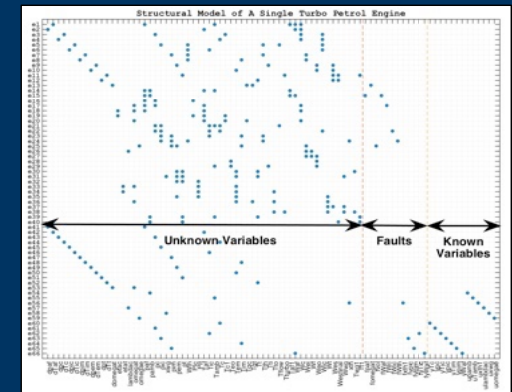
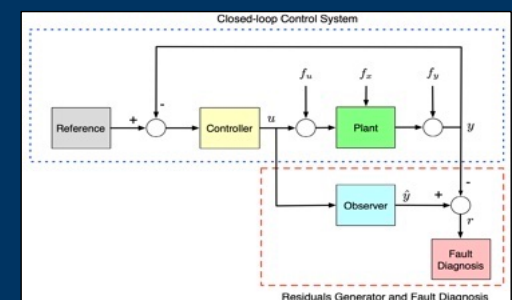
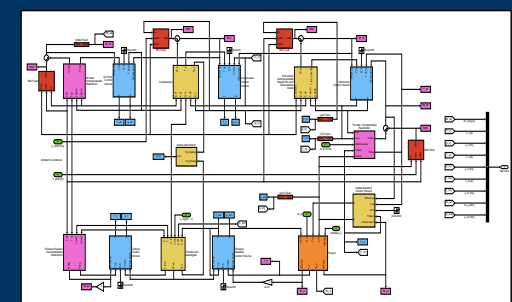
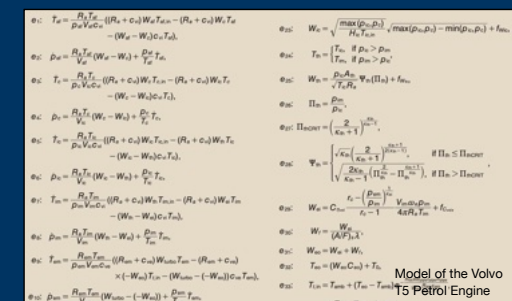
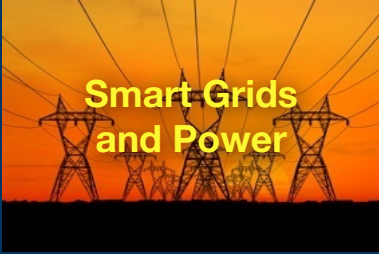

Digital Twin, Digital Shadow, and Simulation Testbed

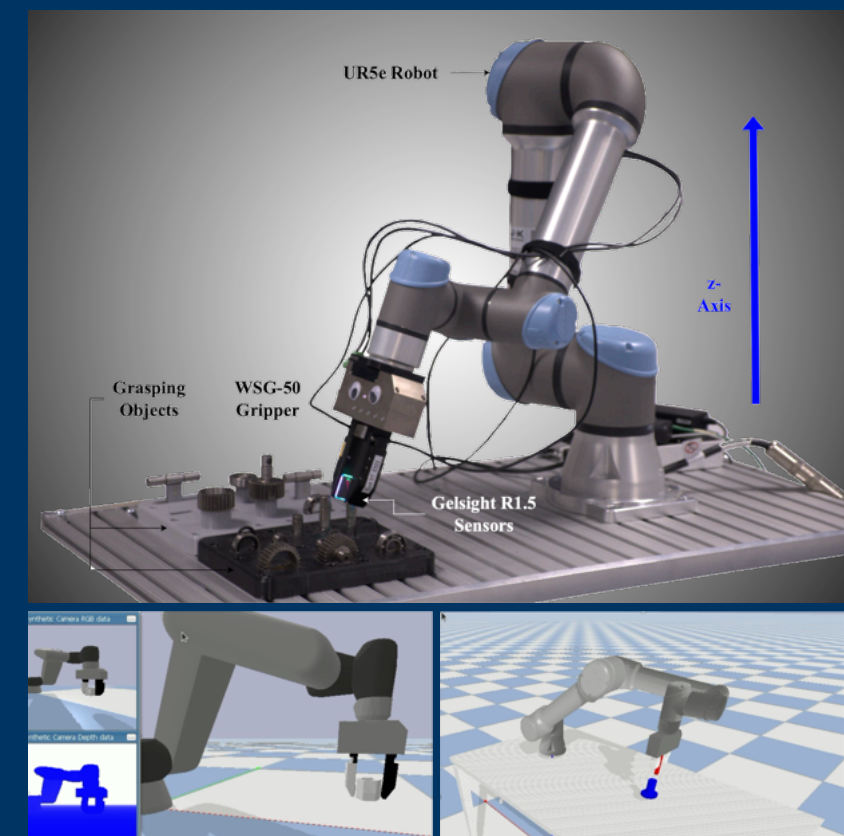
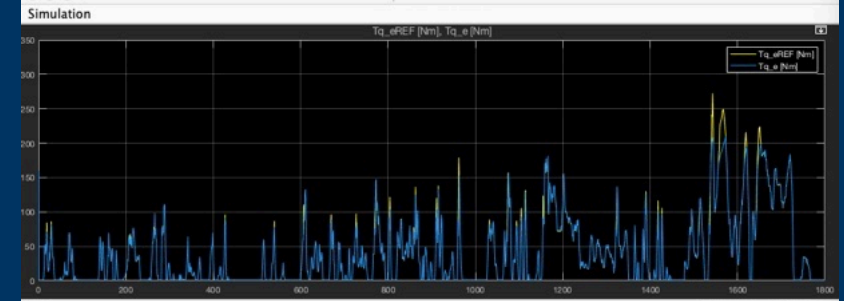
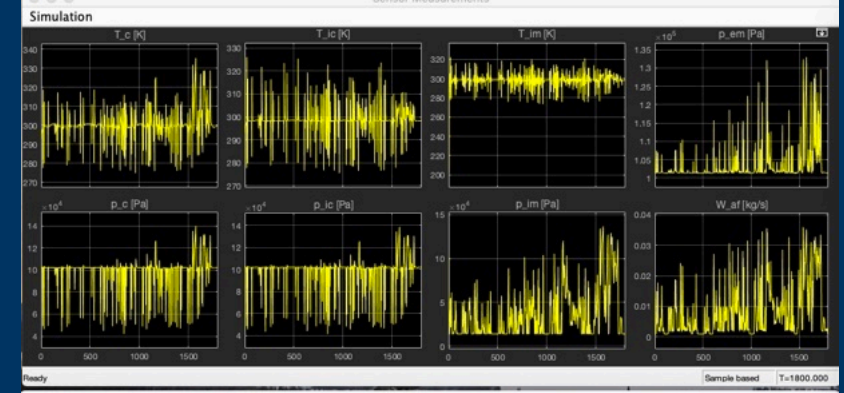
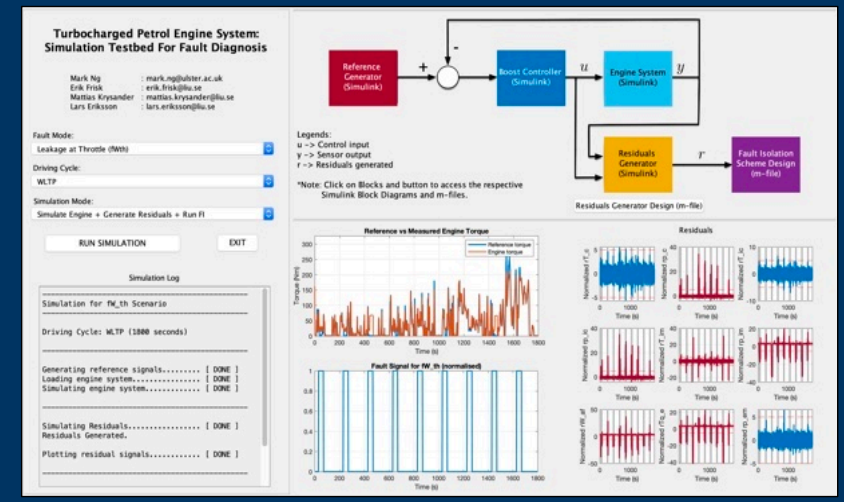

Prediction of Dynamics and Maintenance, Fault/Anomaly Diagnosis, Availability and Sustainability Analysis, Personalised Healthcare, Simulated Surgery, Improved Diagnosis, etc.

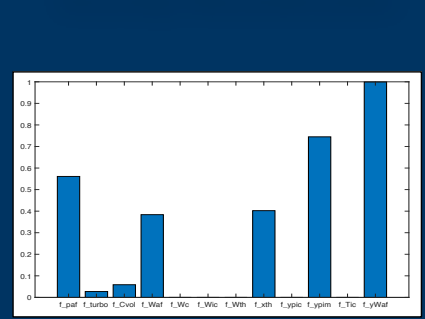
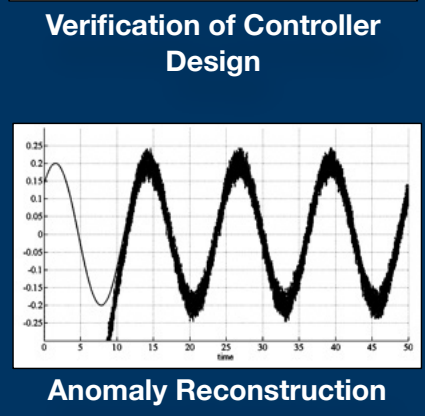
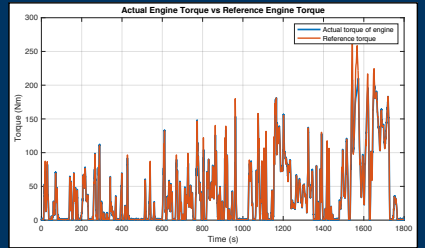
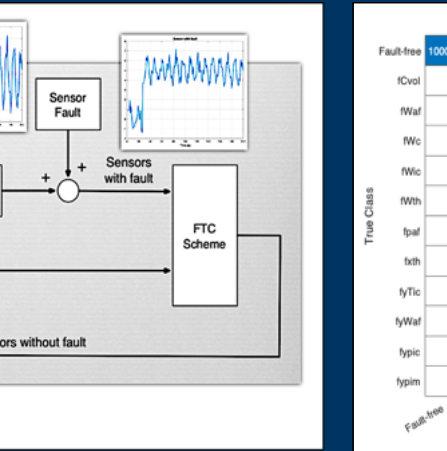
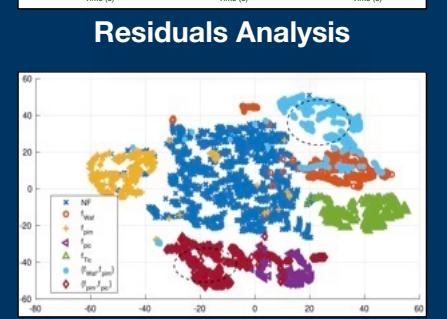
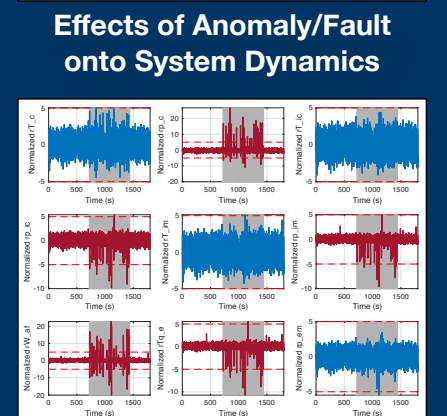
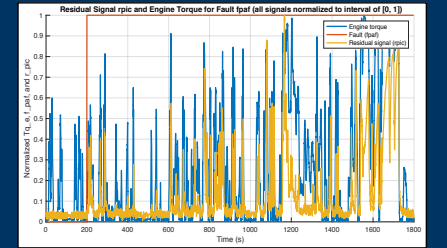
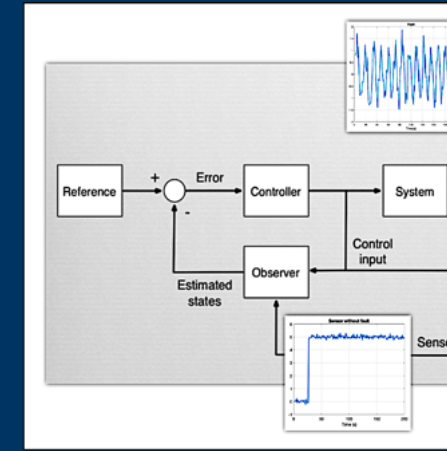
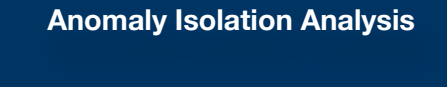
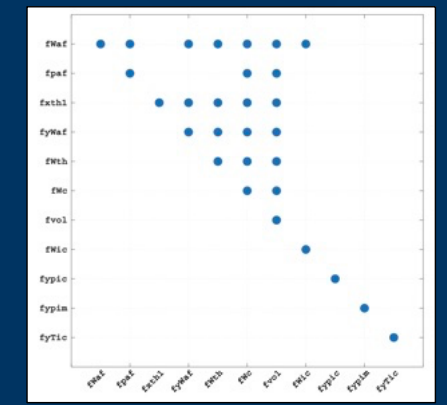
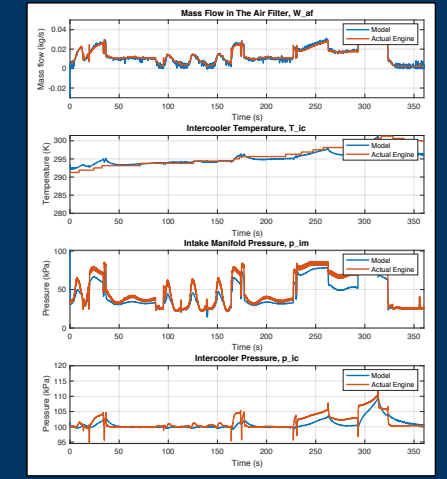

Dr Mark Ng SMIEEE
 Reader and Head of Multi-Agent and Advanced Robotics Centre (MAvRiC), Ulster University
 Senior Adjunct Research Fellow, Monash University
 Vice-Chair, IEEE Control Systems Society (UK&I Chapter)
 ILN+ Researcher in Residence with Digital Catapult
 Email: mark.ng@ulster.ac.uk
 Website: www.markusng.com

Select Key Publications

- "A Realistic Simulation Testbed of A Turbocharged Spark Ignited Engine System: A Platform for the Evaluation of Fault Diagnosis Algorithms and Strategies", *IEEE Control Systems Magazine*, 2020. DOI:10.1109/MCS.2019.2961793
- "Design and Selection of Additional Residuals To Enhance Fault Isolation of A Turbocharged Spark Ignited Engine System", *7th International CoDIT*, 2020. DOI:10.1109/CoDIT49905.2020.9263792
- "Combining model-based diagnosis and data-driven anomaly classifiers for fault isolation", *Control Engineering Practice*, 2018. DOI:10.1016/j.conengprac.2018.08.013
- "A Sliding Mode Observer for Infinitely Unobservable Descriptor Systems", *IEEE Transactions on Automatic Control*, 2017. DOI:10.1109/TAC.2017.2665699
- "A combined diagnosis system design using model-based and data-driven methods", *3rd IEEE SysTol*, 2016. DOI:10.1109/SYSTOL.2016.7739747
- "Predicting Maximum Permitted Process Forces for Object Grasping and Manipulation Using a Deep Learning Regression Model", *8th IEEE CCTA*, 2024. DOI: 10.1109/CCTA60707.2024.10666569
- "Design and Development of a Robust Tolerance Optimisation Framework for Automated Optical Inspection in Semiconductor Manufacturing", *23rd IEEE INDIN*, 2025. DOI:10.1109/INDIN64977.2025.11279663
- "Artificial intelligence in smart manufacturing: Emerging opportunities and prospects", *Artificial Intelligence for Smart Manufacturing and Industry X.0*, Springer Nature, 2025. DOI: 10.1007/978-3-031-80154-9_2
- "A Robust Tolerance Optimisation Framework for Automated Optical Inspection (AOI) in Semiconductor Manufacturing", *DTNet+ SIG*, 2025.
- "Digital Twin of a Turbocharged Spark-Ignited Engine System for Control and Fault Diagnosis", *ITF Summit on Transport Resilience to Global Shocks*, 2025.
- "Learning to Predict Grip Quality from Simulation: Establishing a Digital Twin to Generate Simulated Data for a Grip Stability Metric", *arXiv preprint*, 2023. DOI: 10.48550/arXiv.2302.03504

*Actual simulated and diagnosis results

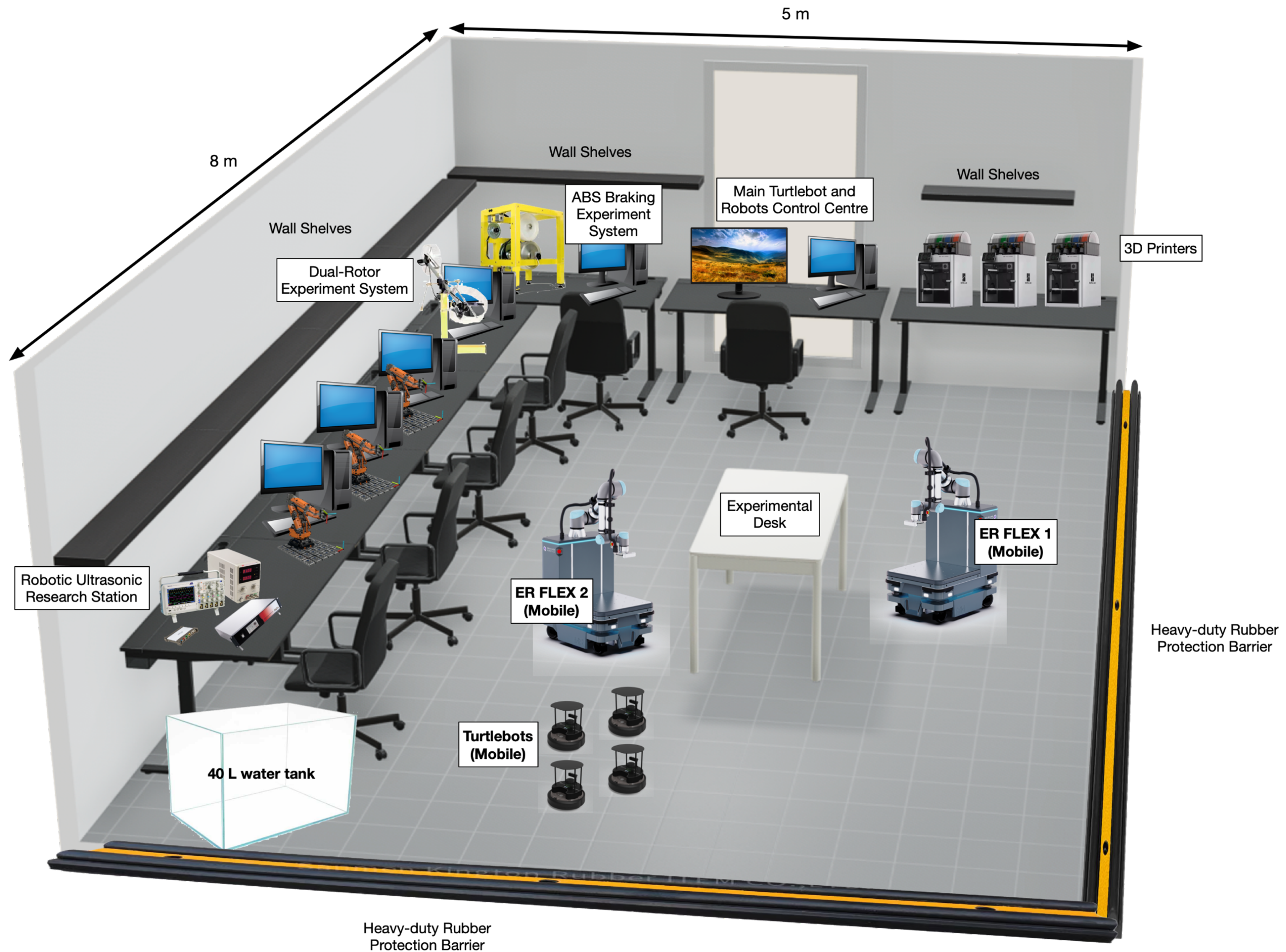

*NOT TO SCALE

Collaborators and Partners



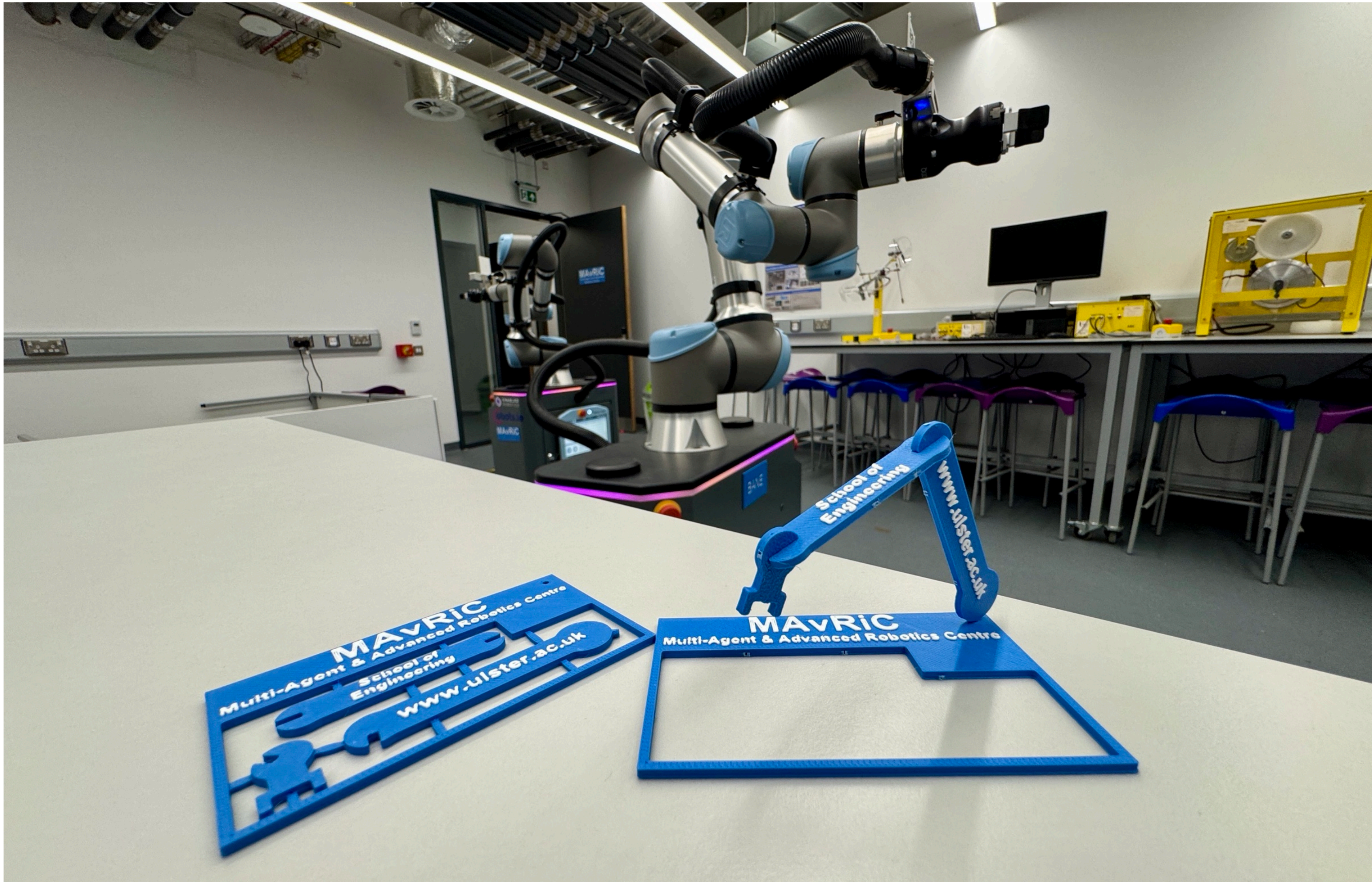

Thank You